



HOLDS AND HATCH COVERS

Produced by
A. Bilbrough & Co. Ltd.



THE LONDON
STEAM-SHIP OWNERS'
MUTUAL INSURANCE ASSOCIATION LIMITED

CONTENTS

Page 2	INTRODUCTION
Page 3	DEVELOPMENT OF HATCH COVERS
Page 15	SAFE OPERATING PROCEDURES
Page 15	Cargo Holds
Page 20	Hatch Covers
Page 20	Opening
Page 23	Closing
Page 25	Special Points to Note Concerning Hatch Openings and Hatch Covers
Page 28	PREVENTING ACCIDENTS TO PERSONNEL
Page 33	EXAMPLES OF CARGO DAMAGE AND PROBLEMS
Page 36	TESTING AND INSPECTION FOR CARGOWORTHINESS AND SEAWORTHINESS
Page 41	HATCH COVER TIGHTNESS AND TESTING METHODS
Page 41	Ingress Leak Test
Page 41	Water-hose Leak Detection Test
Page 42	Chalk Test
Page 43	Putty or Moulding Clay Test
Page 43	Ultrasonic Leak Detection Test
Page 44	Tolerance Test of Hatch Cover Panels
Page 45	MAINTENANCE AND REPAIR
Page 47	Routine Maintenance 1 - After Each Cargo Operation
Page 50	Routine Maintenance 2 - Three Monthly Intervals
Page 50	Mechanical Items
Page 52	Seals
Page 55	Hydraulic System
Page 55	Structure
Page 58	Routine Maintenance 3 - Nine Monthly Intervals
Page 59	Pre-docking Checks
Page 59	Pre-delivery Checks
Page 59	Repairs, Emergencies and Normal Practice
Page 60	DO'S AND DON'TS

Introduction

This booklet highlights some of the common causes of damage, loss and personal injury associated with cargo holds and hatch covers. It will help you operate and maintain the holds and hatch covers on your vessel safely and cost effectively.

**"CAUSE OF LARGE CARGO CLAIMS BY VALUE"
DRY BULK AND GENERAL CARGO VESSELS**

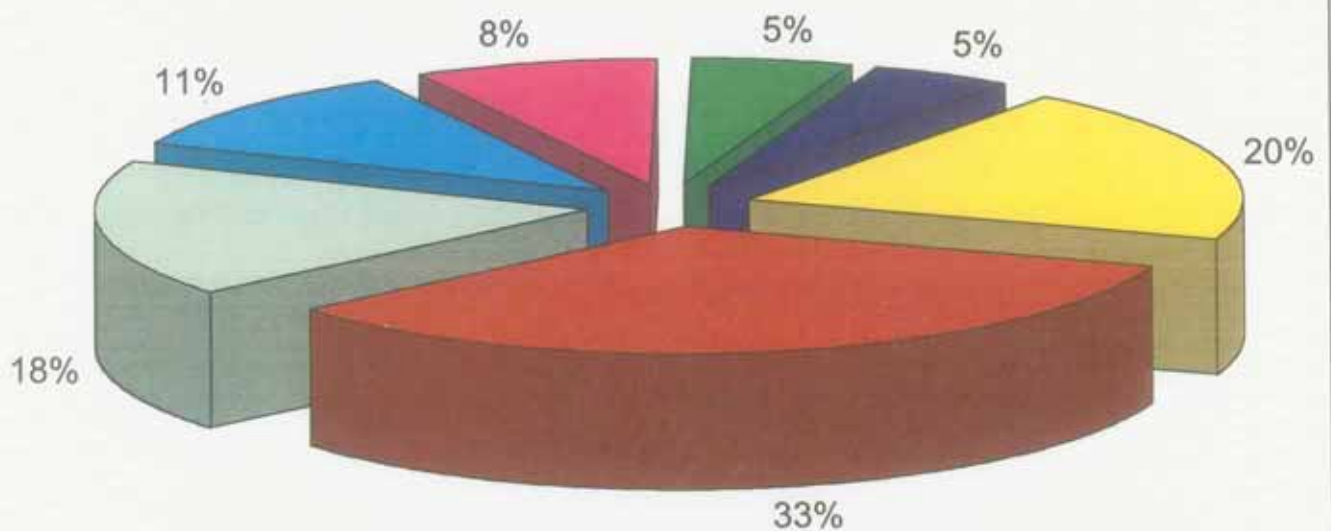

- 5% PIPE FAILURE IN HOLD
- 20% CARGO OR DOCUMENTS FAULTY
- 33% HATCH COVER LEAKS
- 18% SHIP STAFF FAULT
- 11% ENGINE ROOM PROBLEM
- 8% CARGO STOWAGE PROBLEM
- 5% STRUCTURAL FAULT

Development of Hatch Covers

Hatch cover design is continually evolving to meet changing trading needs.



Photo: MacGREGOR

Single pull wire operated hatch covers.

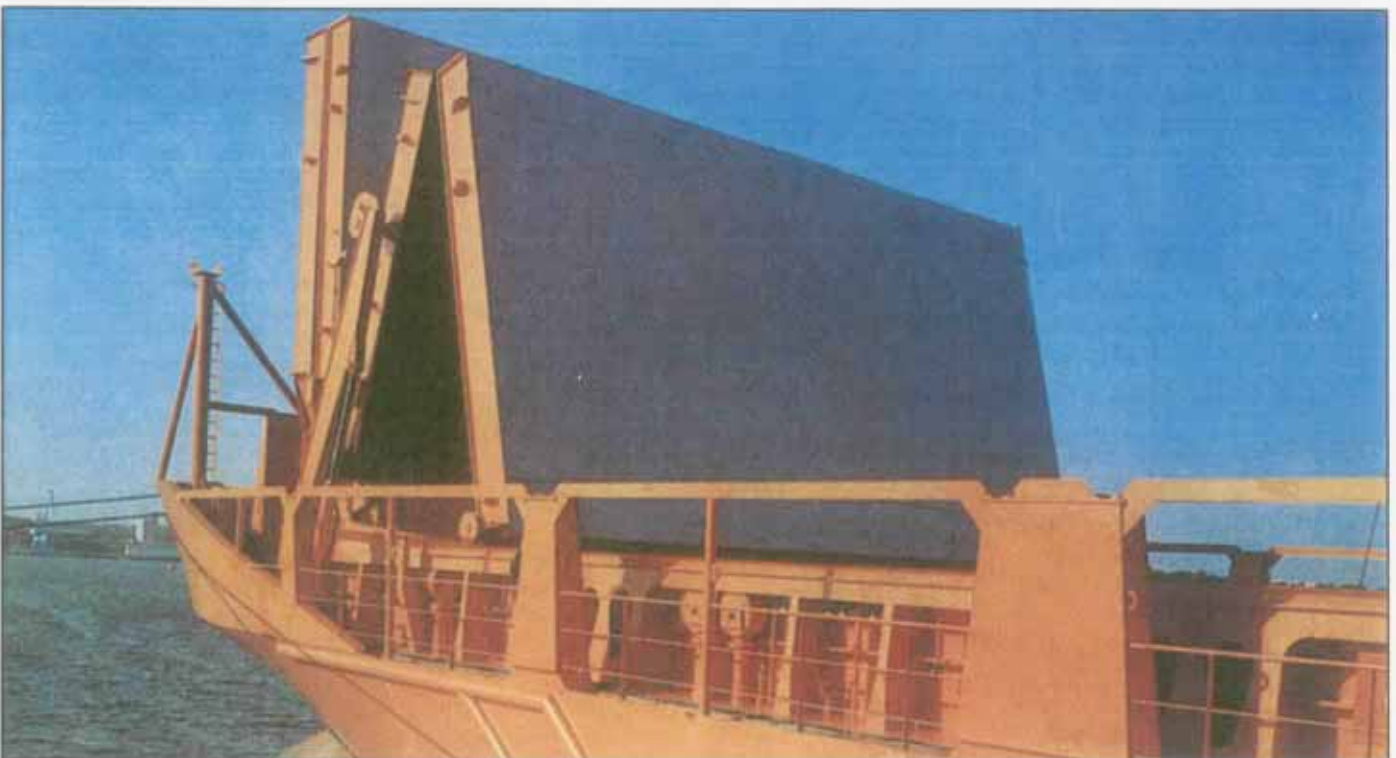

Photo: MacGREGOR

Hydraulic hatch covers became the most popular.



Photo: MacGREGOR

Size and strength requirements led to side rolling covers.



Photo: MacGREGOR

Stacking or multi-folding covers were developed for coastal trades.



Photo: MacGREGOR

Large pontoon covers for containerships can carry the weight of high stacks of containers.

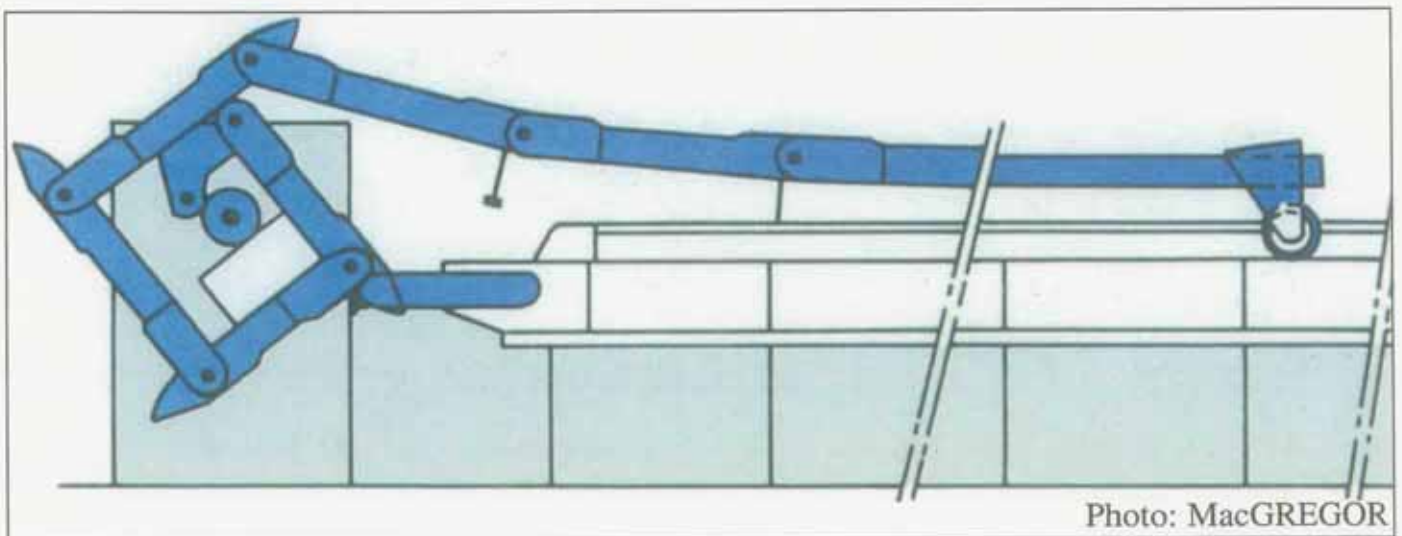
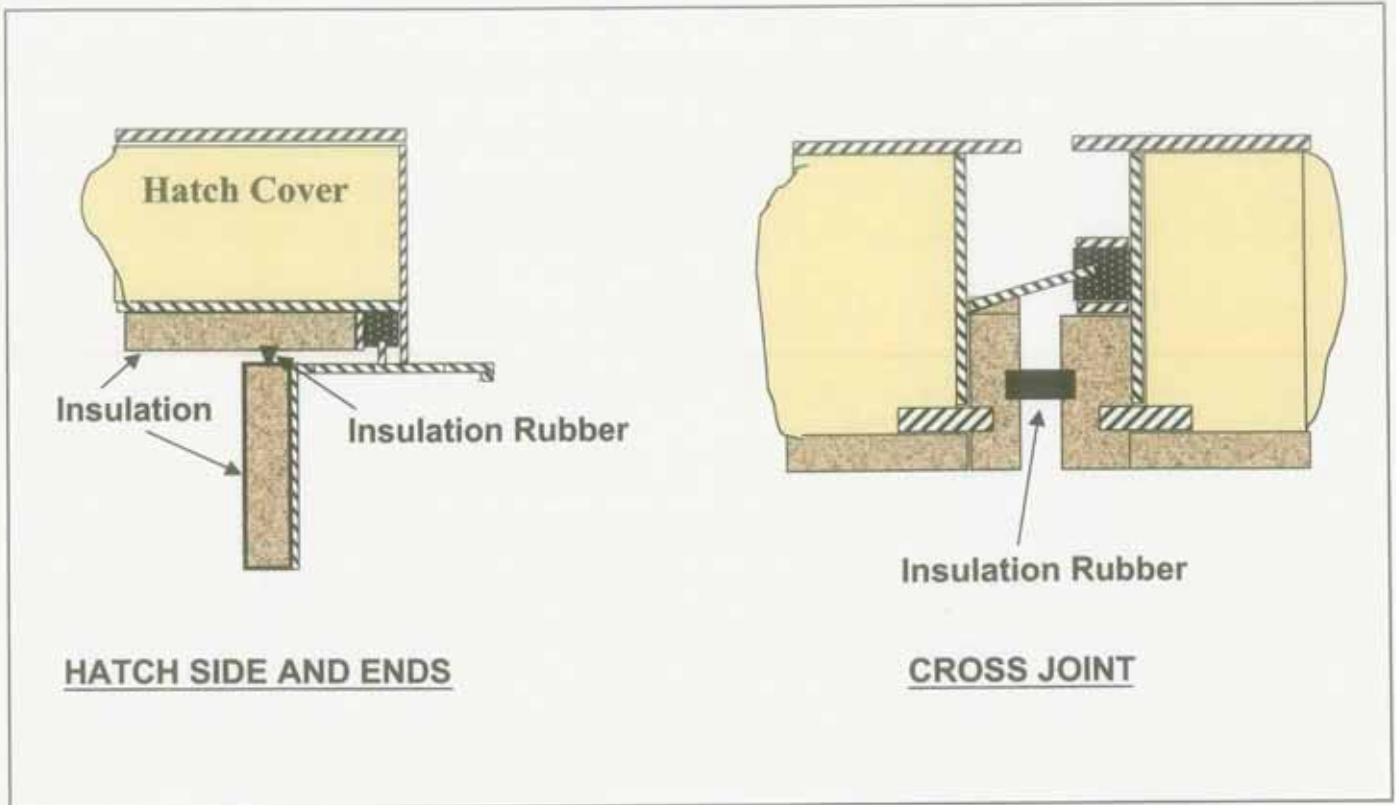

Photo: MacGREGOR

Drum stowing "Rolltite" hatch covers were developed for ease of handling and to save space.



Insulated covers for refrigerated cargoes have special sealing systems.



Photo: MacGREGOR

Aluminium coiling covers are used on inland waterways and canals.

Open frame construction

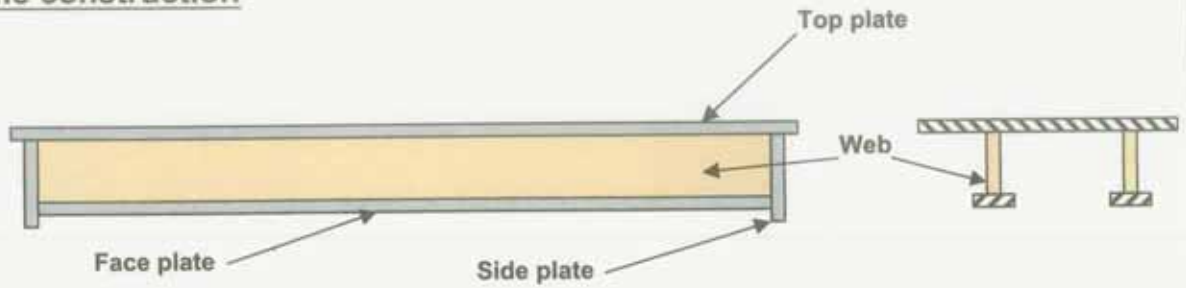

Double skin or box construction

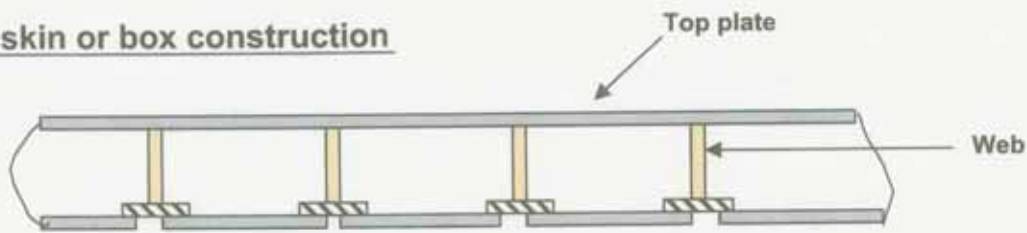

Double skinned or box type covers were developed to span large openings. They provide equivalent strength to those with open construction without protruding so far down into the cargo space and losing cargo carrying capacity.



Photo: MacGREGOR

'Tween deck hatch covers need to be even stronger as they take the weight of cargo laden forklift trucks.

Bigger ships meant more flexing of the hull and caused cleats and locking/retaining systems to develop and provide the necessary retaining forces.

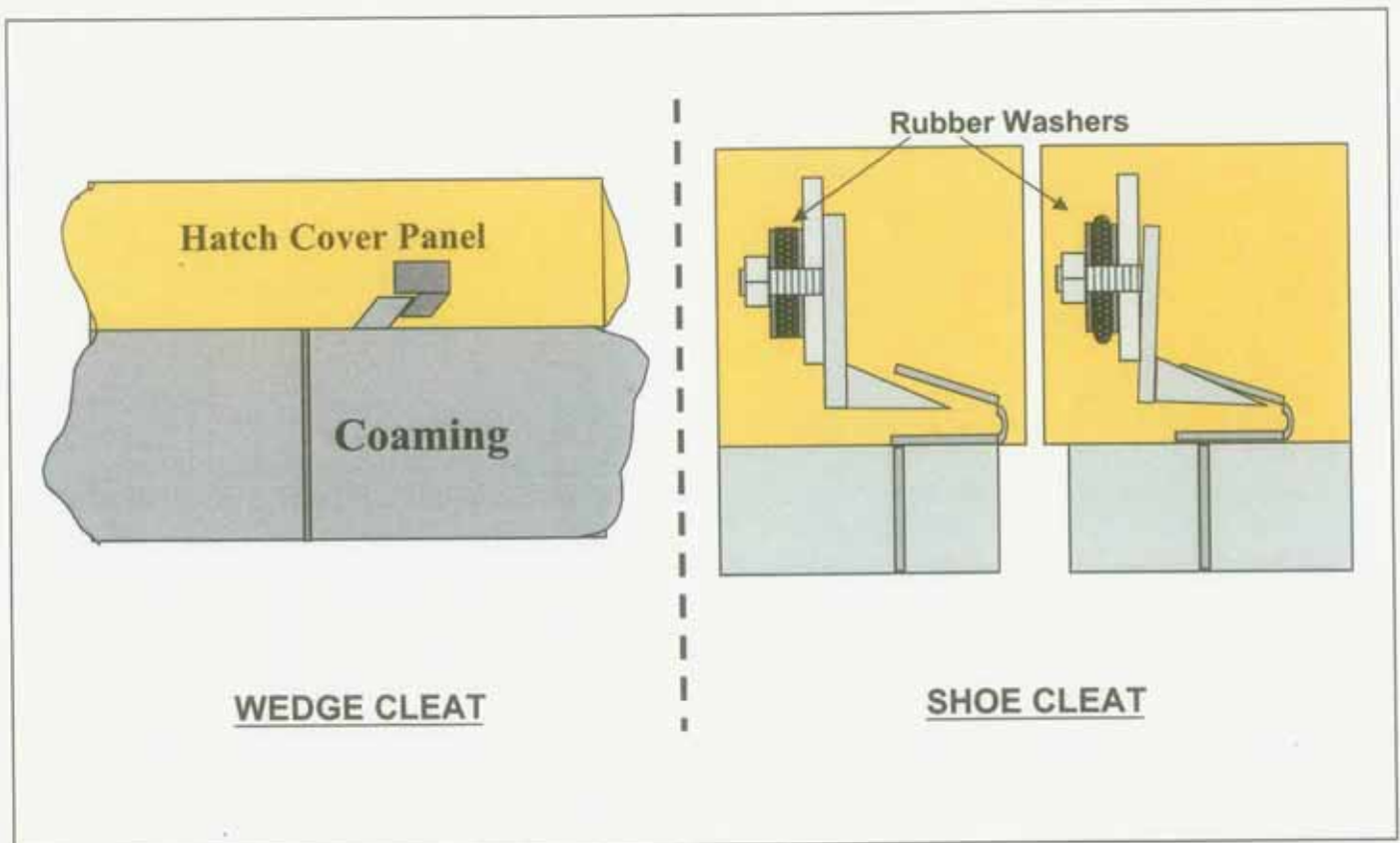
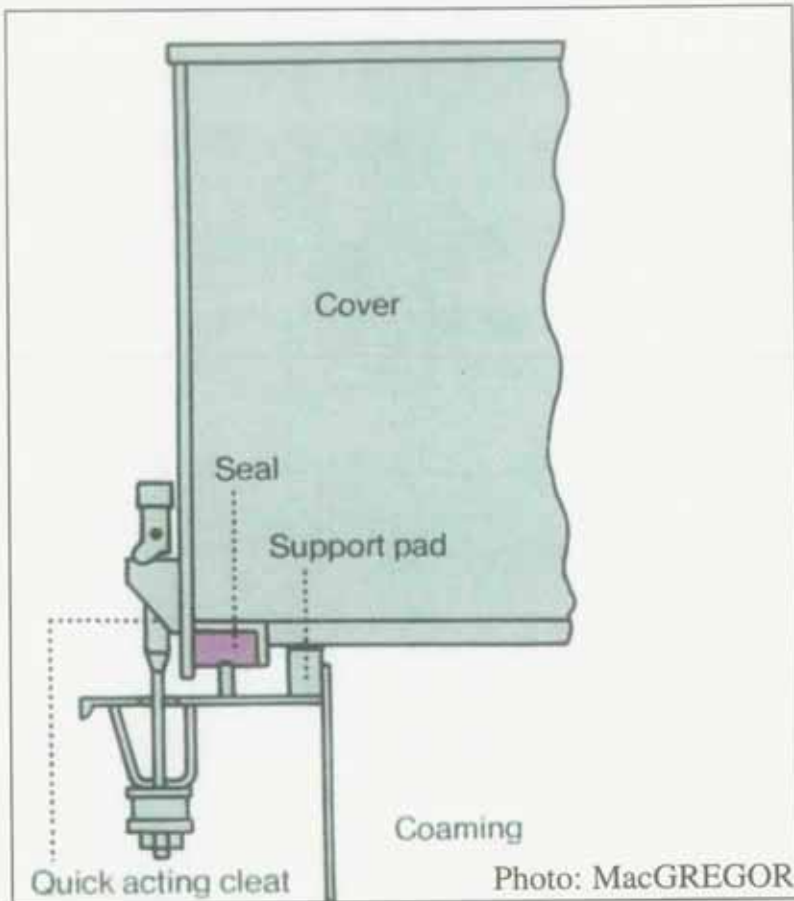

The reduction in crew necessitated less labour intensive securing arrangements and the auto-cleat system was developed.

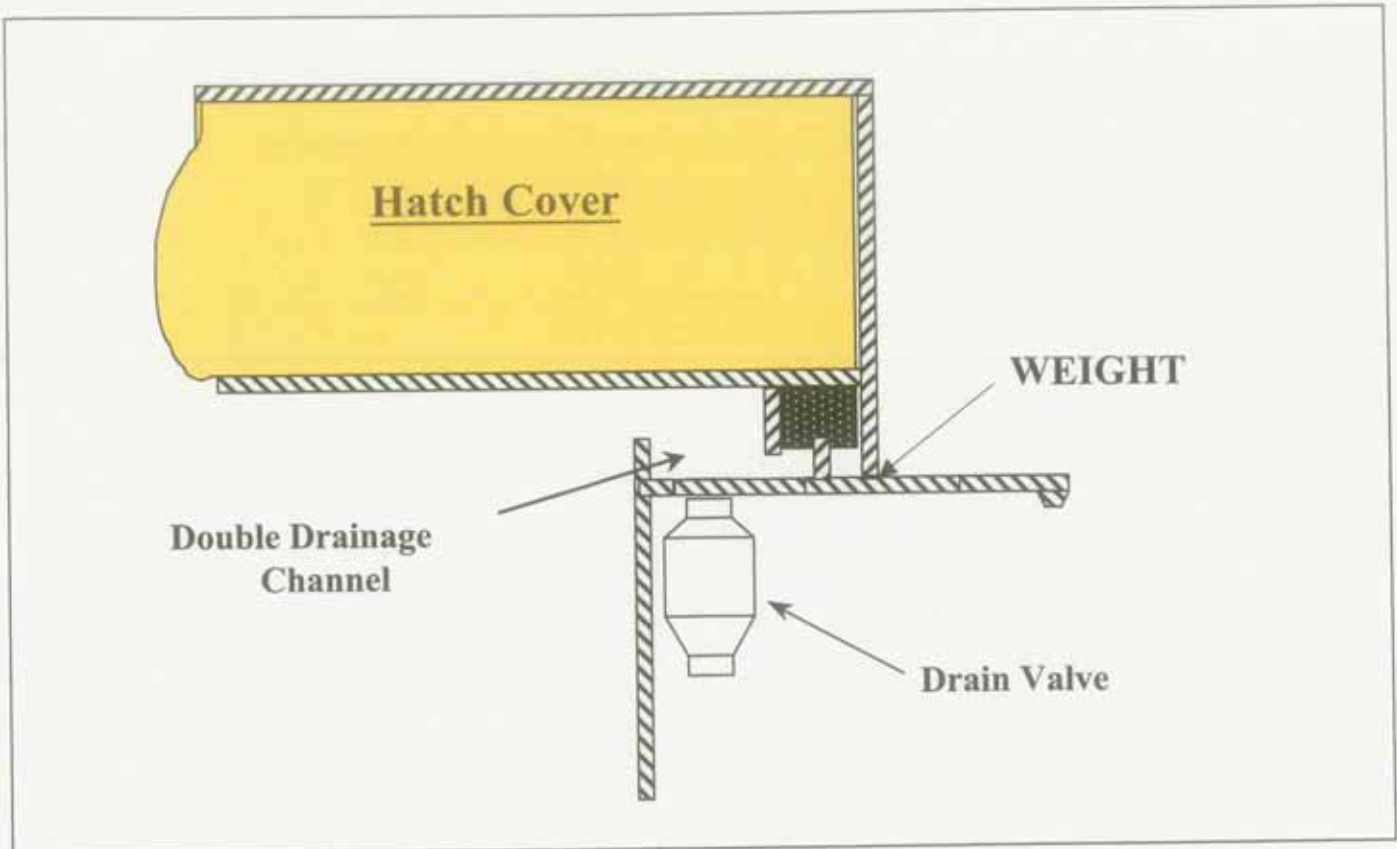

The weight of some hatch covers is taken by the side-plate edges onto the coaming top.

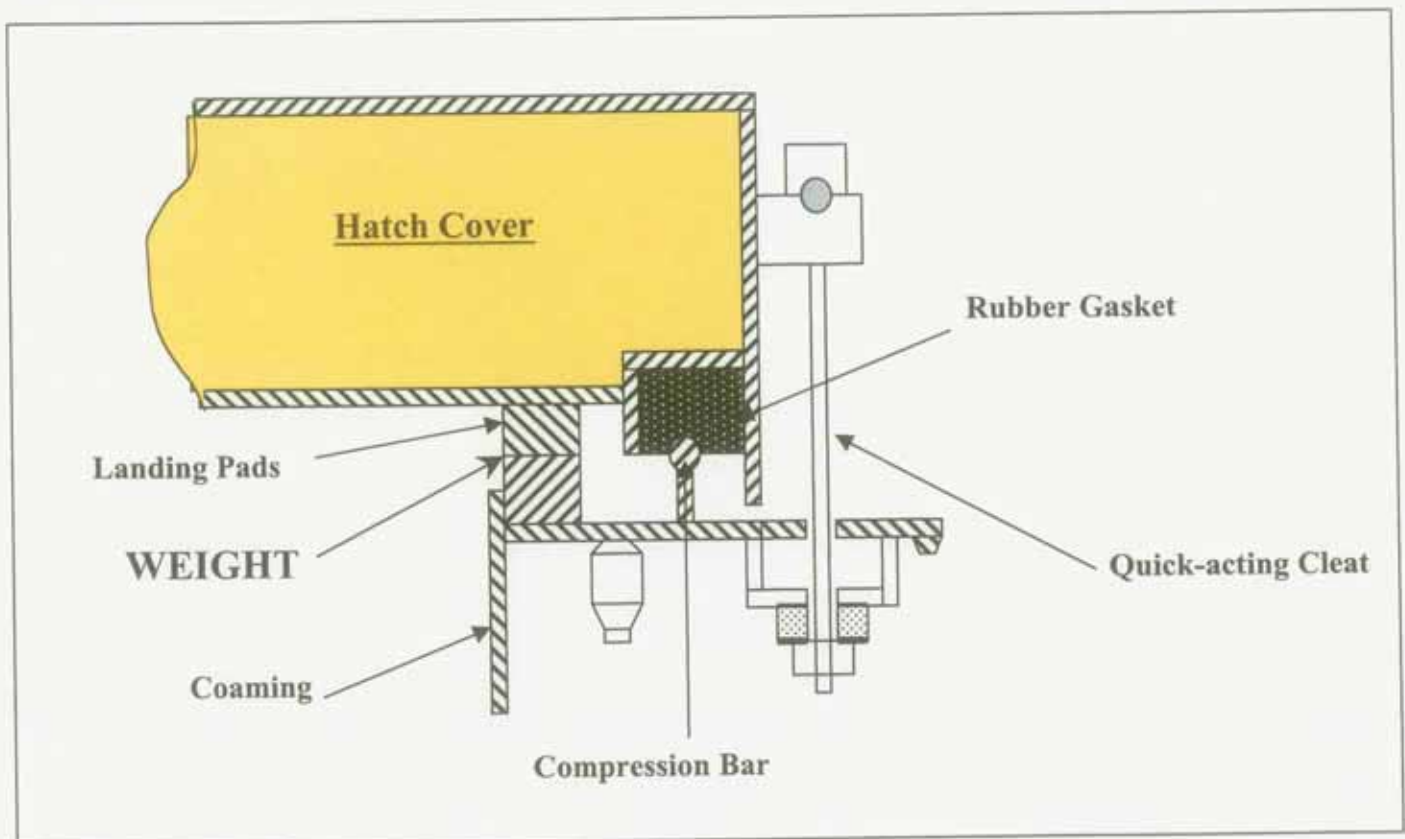

Heavier hatch covers led to landing pads being developed to take the weight. These also had the effect of improving weight transferral of any hatch top deck cargo into the ship's hull.

Steel-to-steel contact between the hatch cover and coaming is normally created by the weight of the panel and not by the tightening of the cleats. Today these landing pads can be made from highly wear-resistant materials, such as the one shown below.

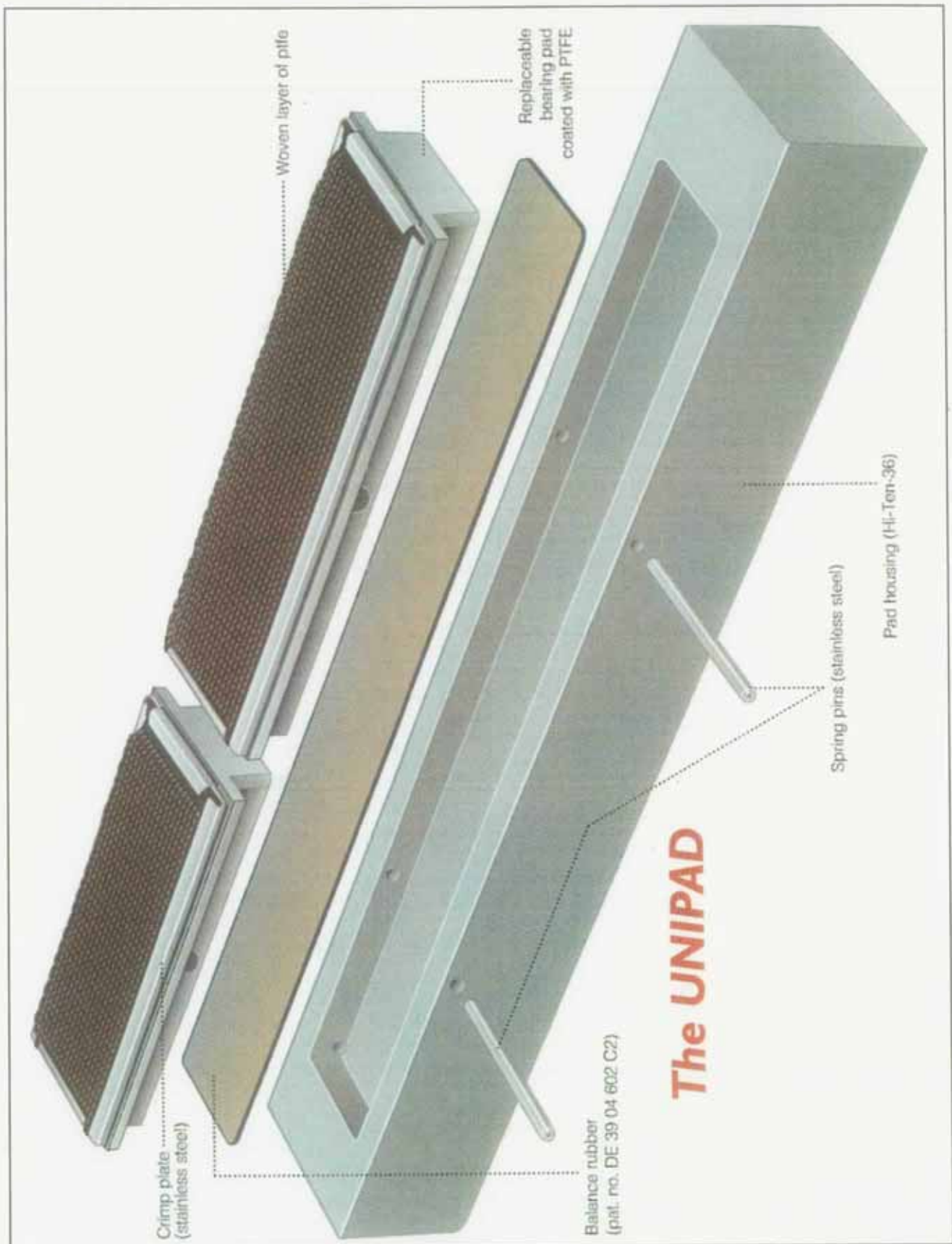
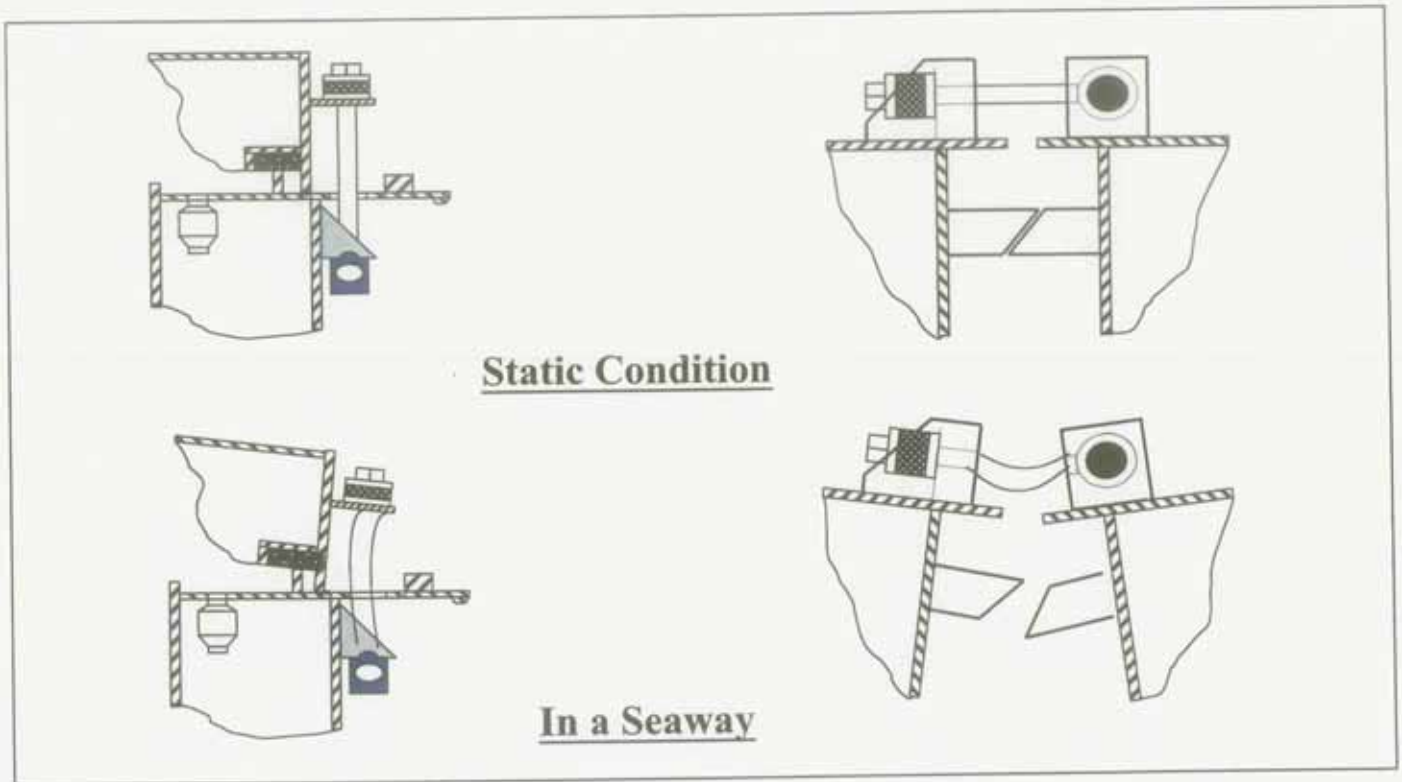
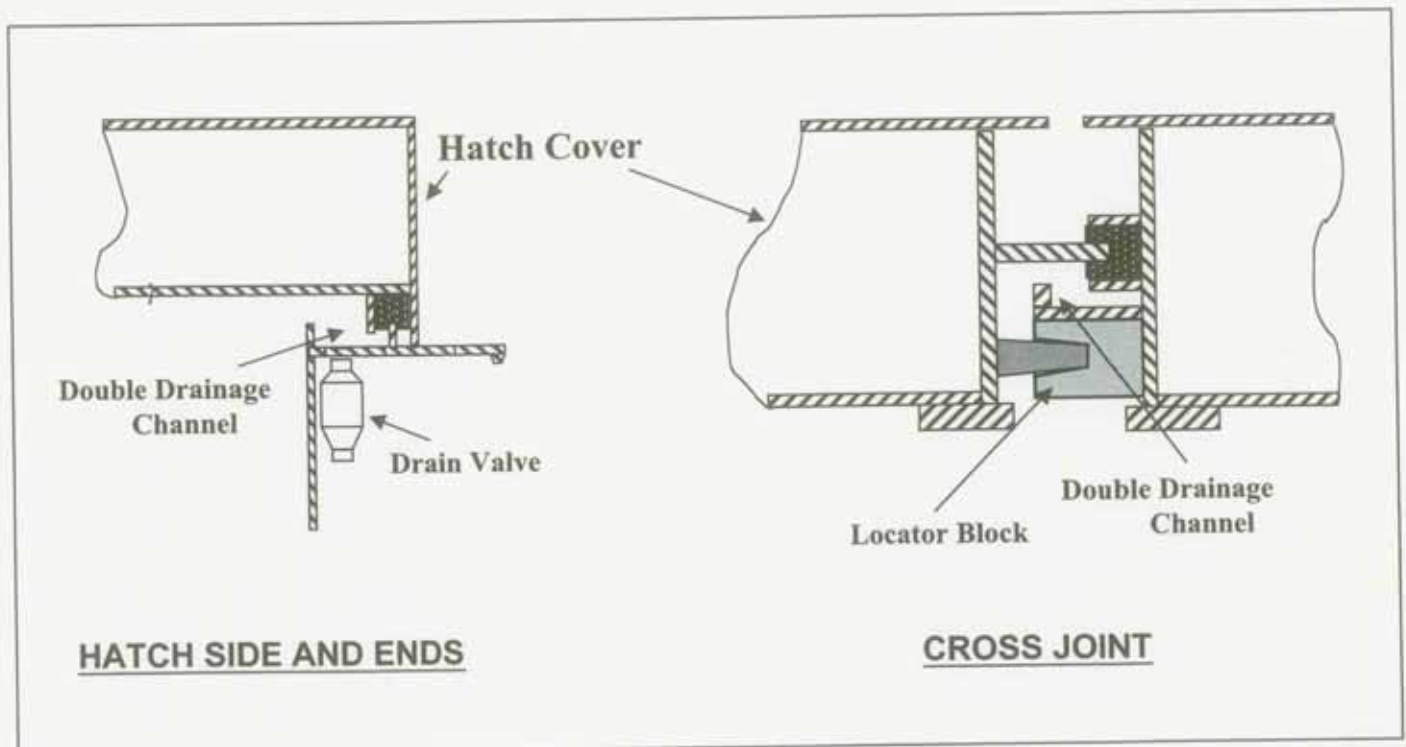

Photo: MacGREGOR



The cleats are used to restrict the movement of the hatch cover pontoon in a seaway. The effects are shown above.



Double drainage is important to lead minor leakage away through the drain valves and is an essential component in the weathertight integrity system.

In most systems the hatch cover weathertight seal is obtained when a compression bar seats into rubber packing.

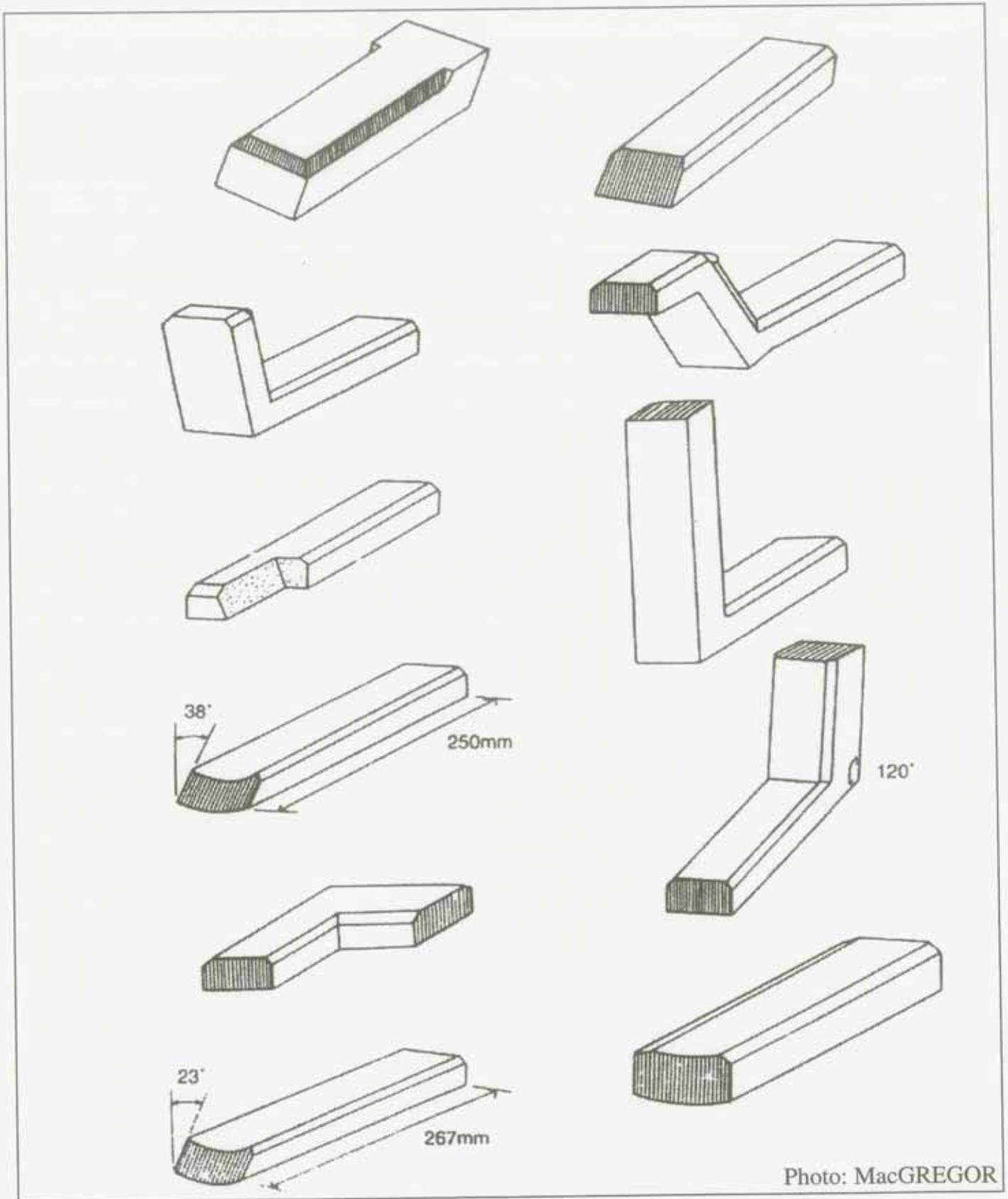
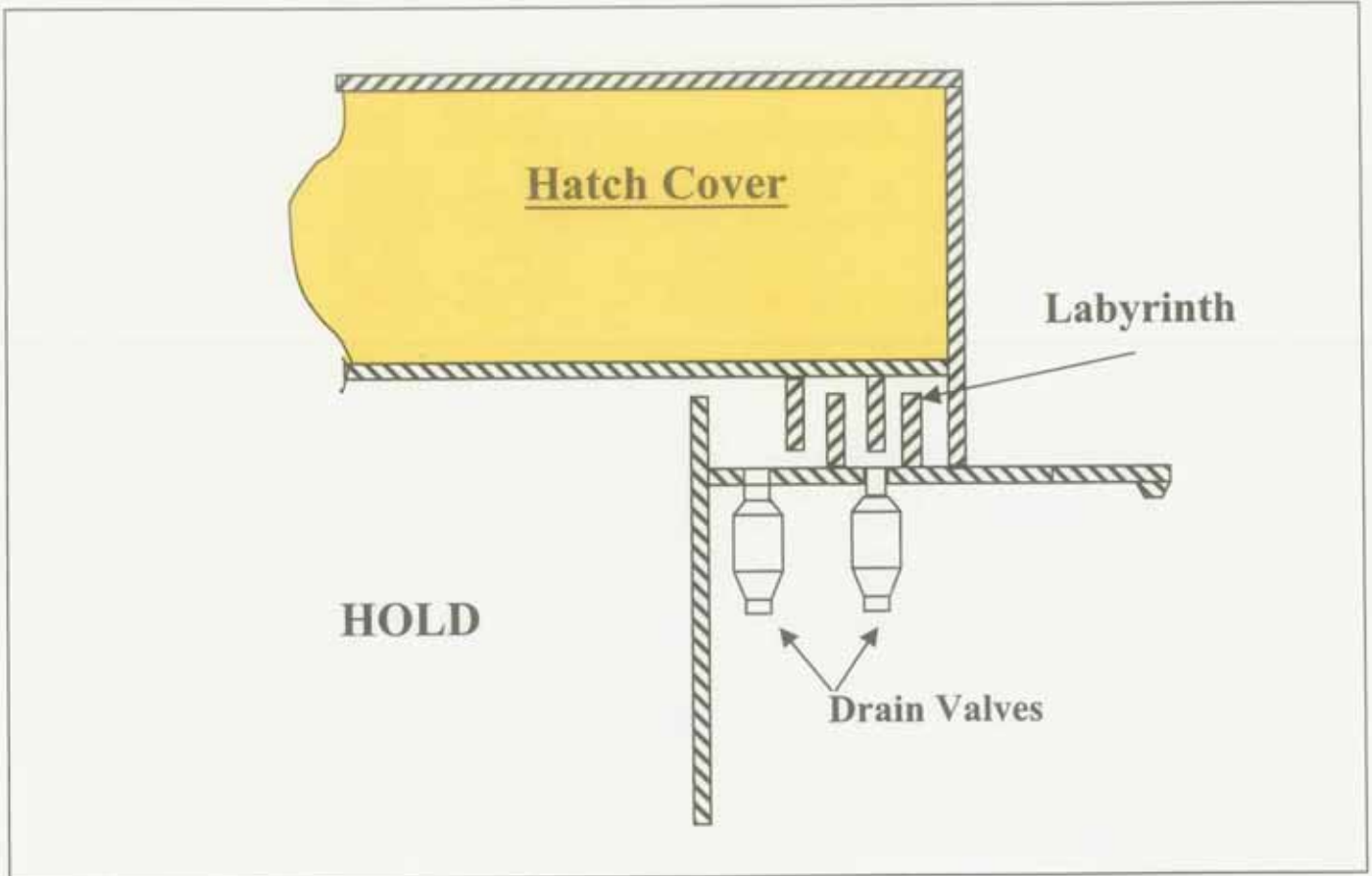

Photo: MacGREGOR

There are various pre-shaped forms of linear rubber packing and it is important to use the correct piece. Check the original specifications when ordering replacement parts.

If the ship's function has changed seek advice from the manufacturer on the type of packing to use.



The sealing system may also be designed with a labyrinth system or rubber skirts.

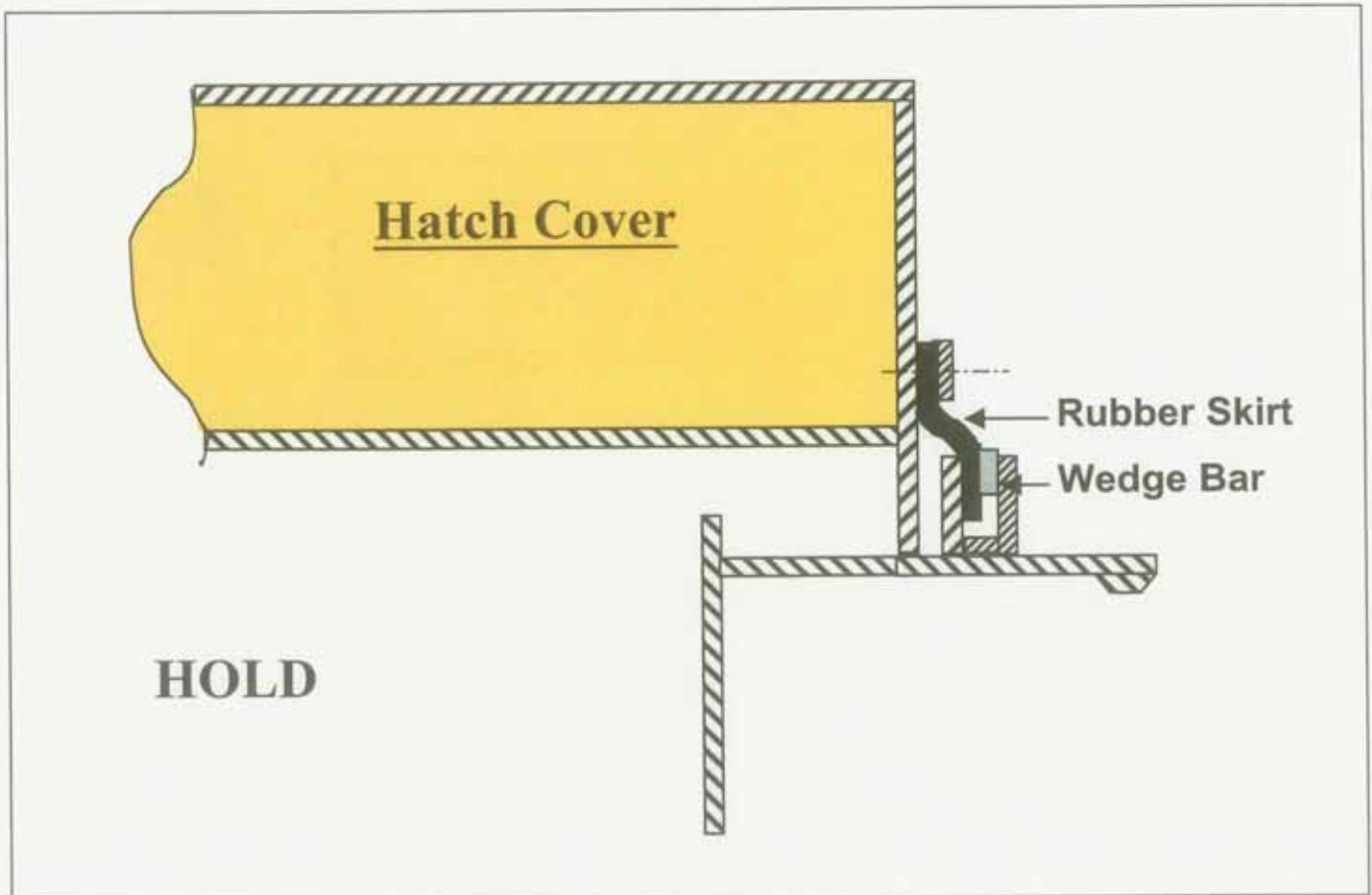

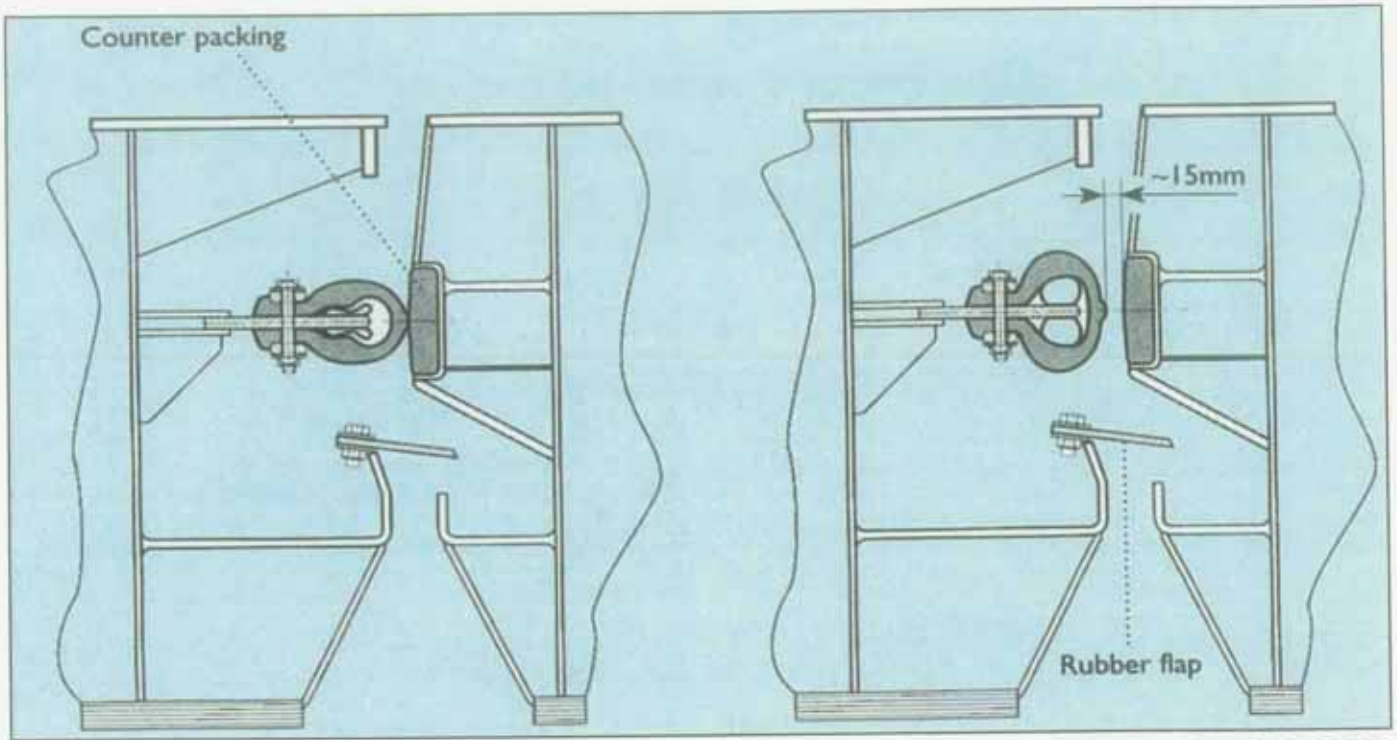
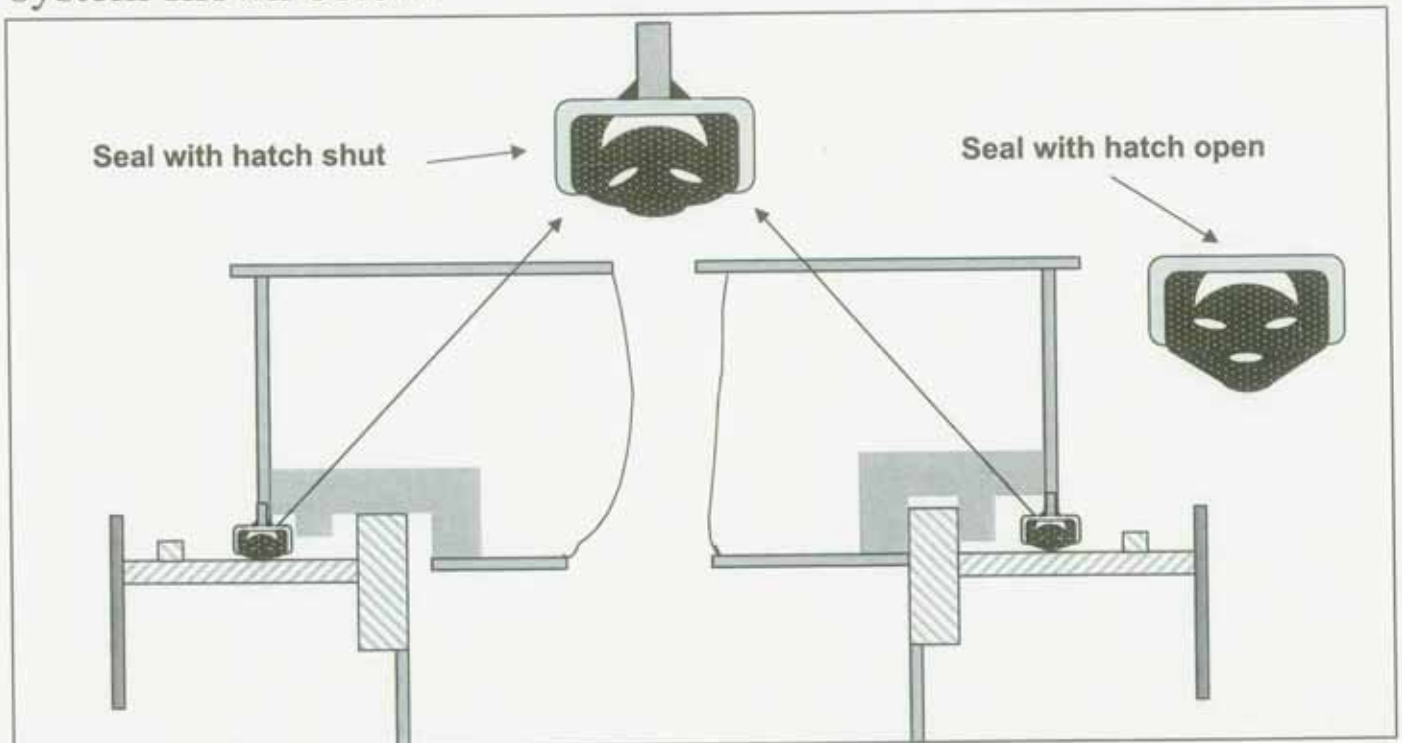

Photo: MacGREGOR

Sliding rubber systems do not use compression bars and allow greater movement between coaming and hatch cover. The Omega sealing system is shown above with the Cat sealing system shown below.



Compression bars made of highly corrosion resistant material were introduced to reduce on-going maintenance to both the bars themselves and also the sealing rubbers. The extra initial cost is many times cheaper than subsequent replacement parts and labour, not to mention the reduced potential for cargo claims.

Safe Operating Procedures

Cargo Holds

ISM Code systems should include procedures for loading, unloading, ballasting, deballasting, securing manholes, blanking ballast lines, testing bilge systems, testing alarms and even hold cleaning in preparation for the next cargo. Safely following these procedures and recording details in relevant logbooks is very important.

Watch these basic points:

- Relevant crew members must familiarise themselves with the type of cargo being carried and any special procedures, taking particular note of any special ventilation or care requirements.

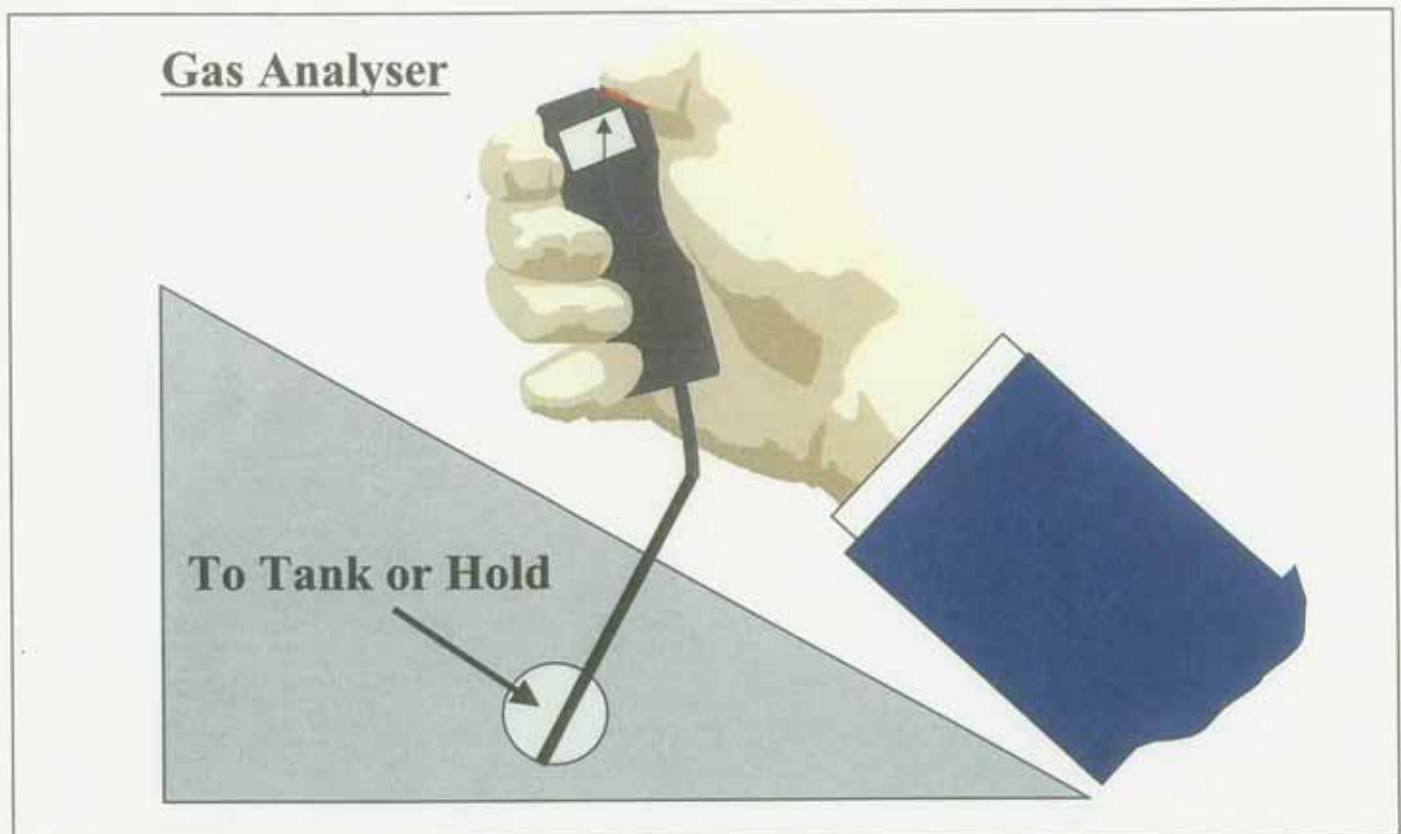

- When hold cleaning beware of toxic gases from the previous cargo. Check the hold atmosphere.
- Watch for tools or equipment falling on crew below.

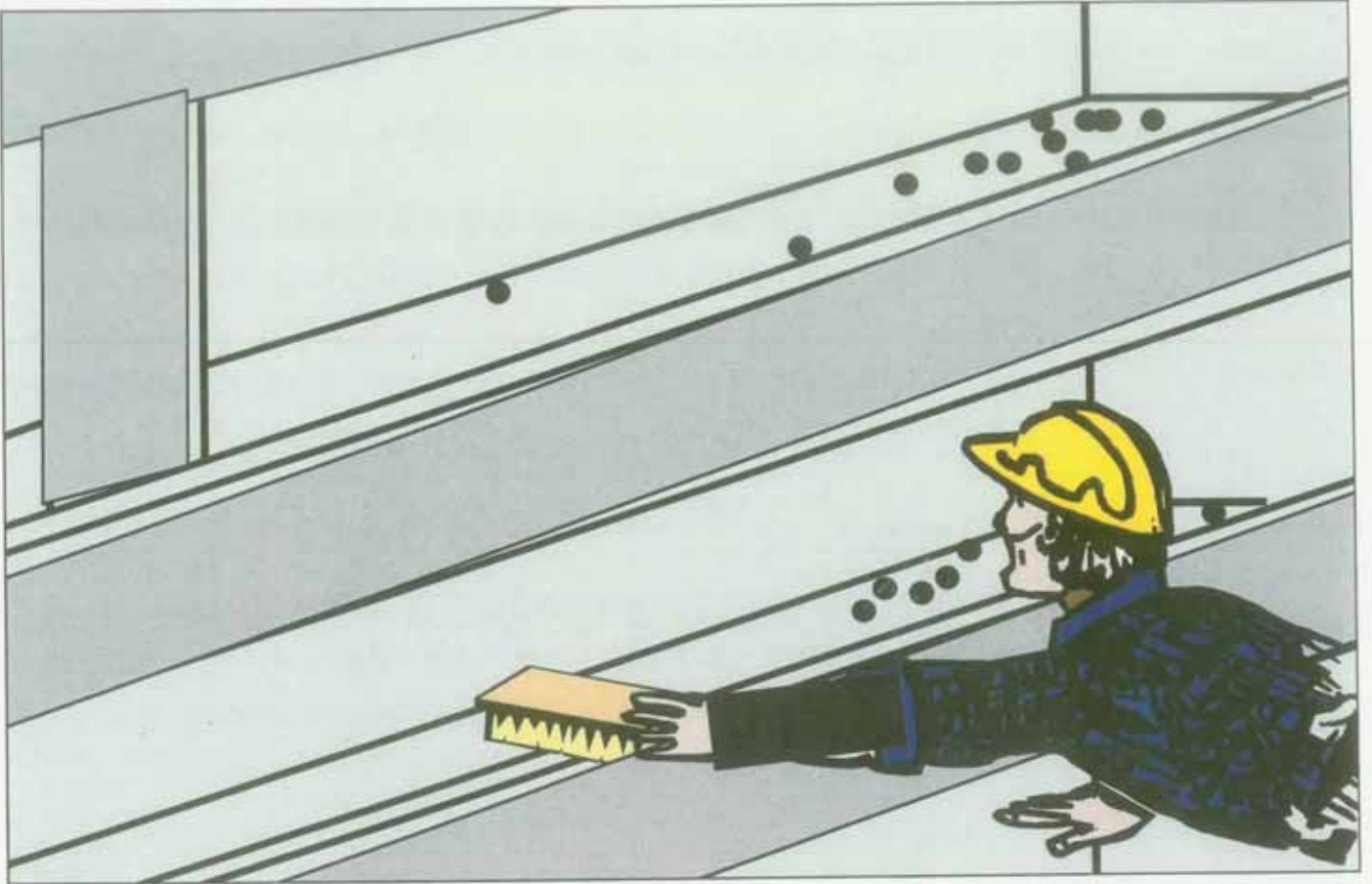

Always clean cargo residues off hatch cover frames.



Check bilge suction and sounding pipes to the hold bilge wells and ensure they are clear of debris.



- Test bilge-pumping arrangements, including non-return valves.
- Test bilge alarm system.
- Ensure personnel are not in the holds or tanks when ballasting or bulk loading.
- Remove all tools, buckets and other gear on completion.
- Keep an eye on shore workers and visitors to the vessel and make sure they follow the safety rules.

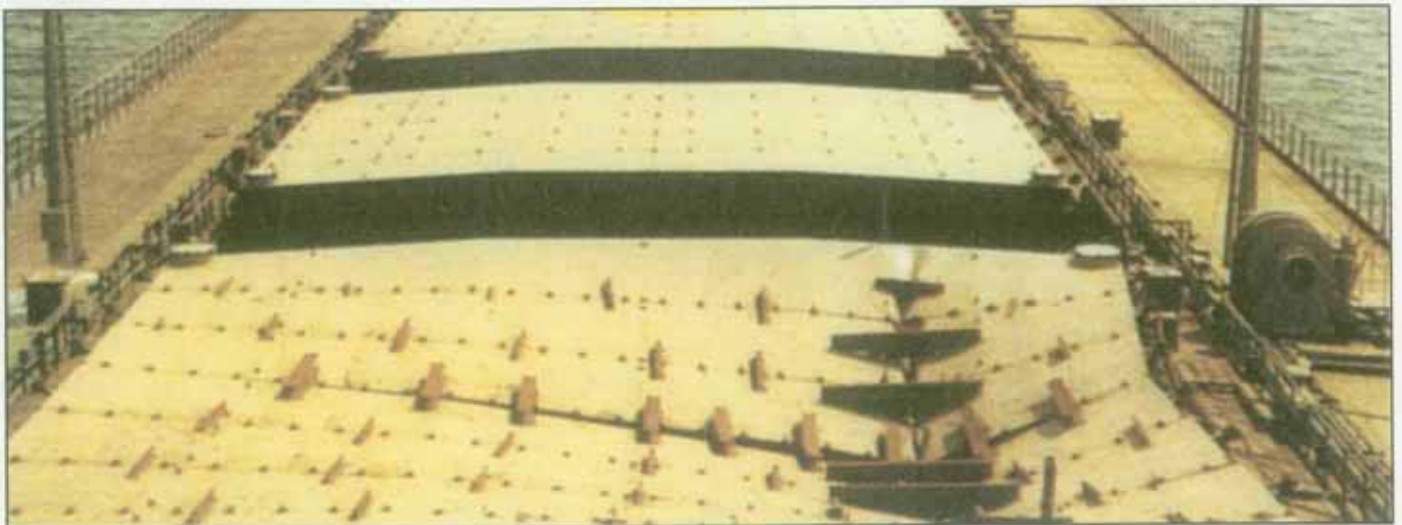
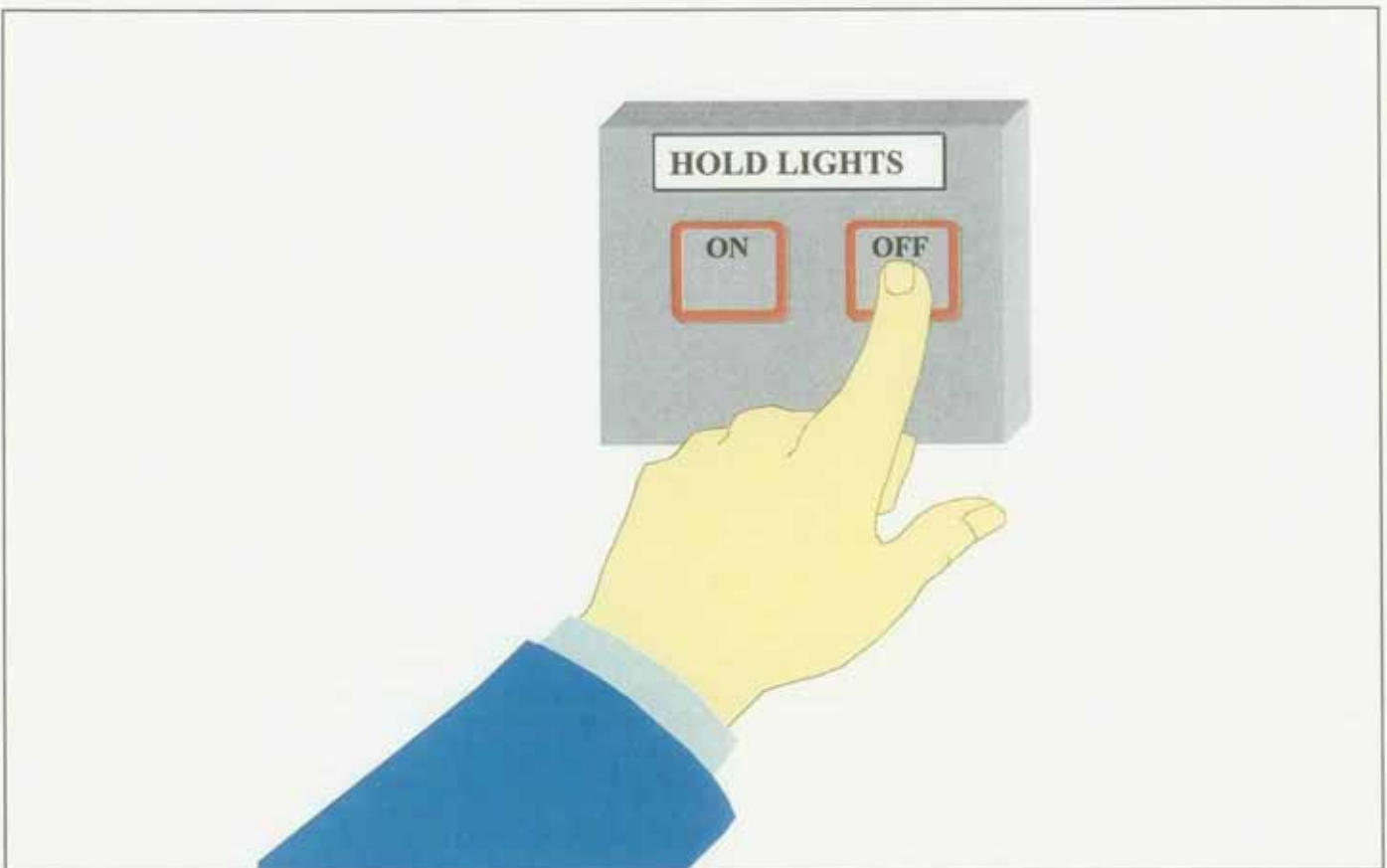

Photo: MacGREGOR

- Check ventilation lines are open and free to the ballast hold, then monitor ballasting and deballasting operations continuously.



- Take precautions if loading sensitive cargo against heated bulkheads, bunker tanks or engine room.



- Ensure hold lighting is switched off when not in use and remove fuses on a laden passage.

Hatch Covers

Accidents often happen when hatch covers are moved. Make sure you have the maker's operating instructions for the hatch covers on your ship and follow them.

Watch these basic points:

Opening



Prior to opening, the Officer of the Watch must be informed.



Never open more than one set of hatch cover panels at a time.

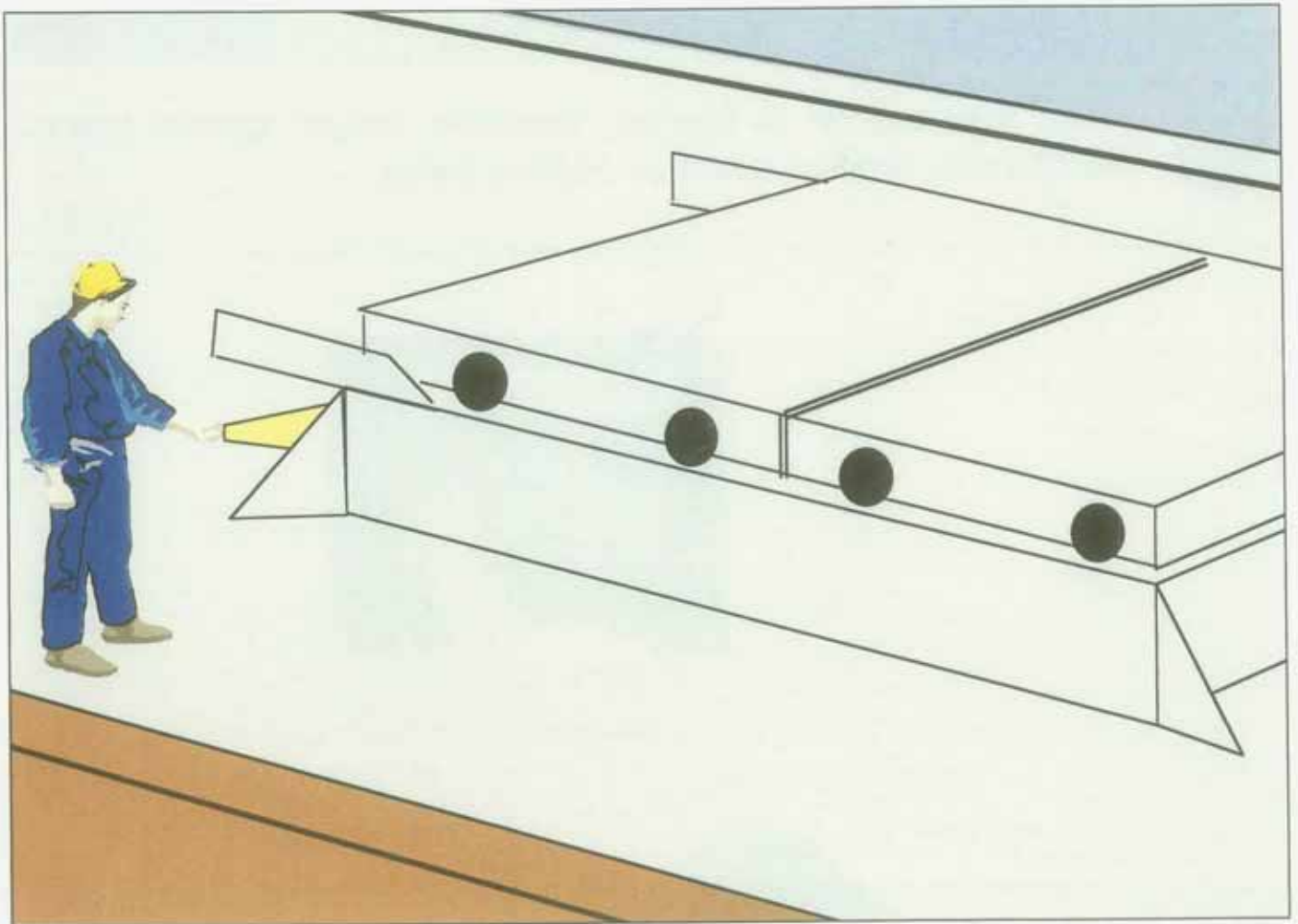

Check that the hatch cover panel stowage area is free of personnel, equipment or dunnage.

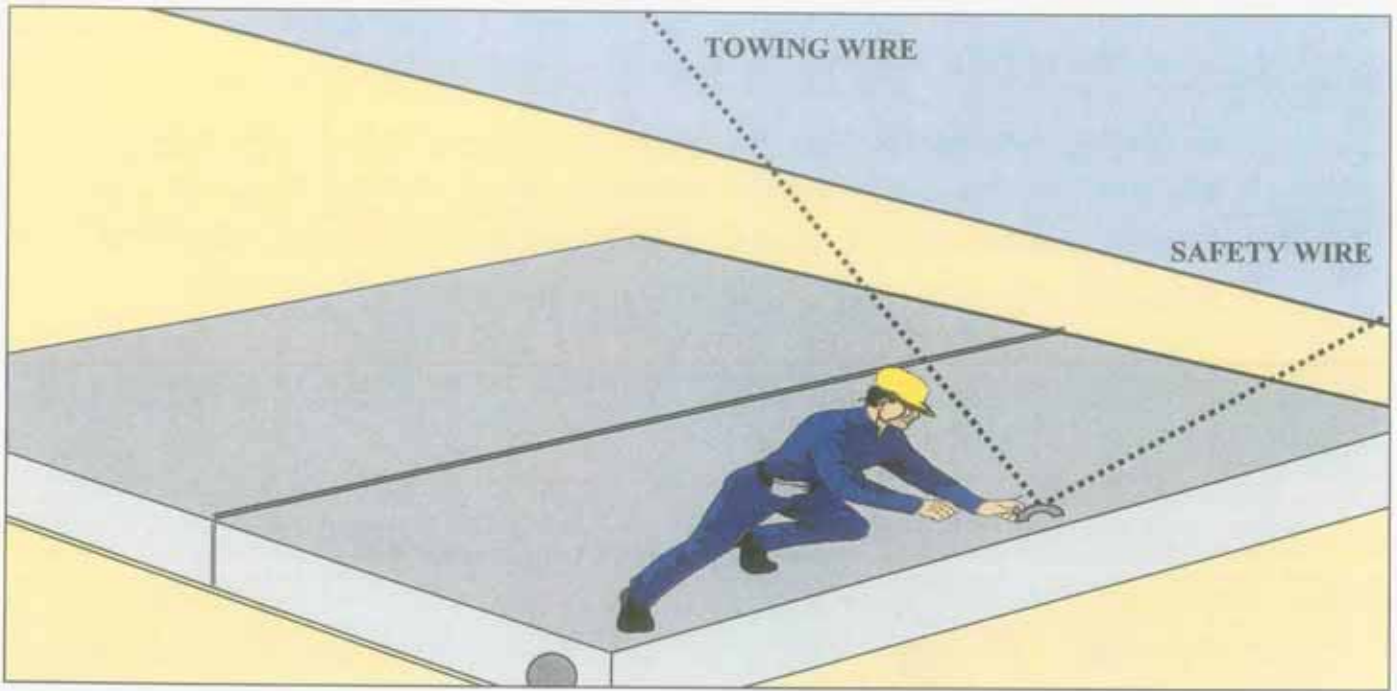

- Attach safety check wires or switch on the power system, with controls correctly positioned, prior to removing cleats.
- Disengage all cleats.
- Ensure personnel are clear all round the hatch.

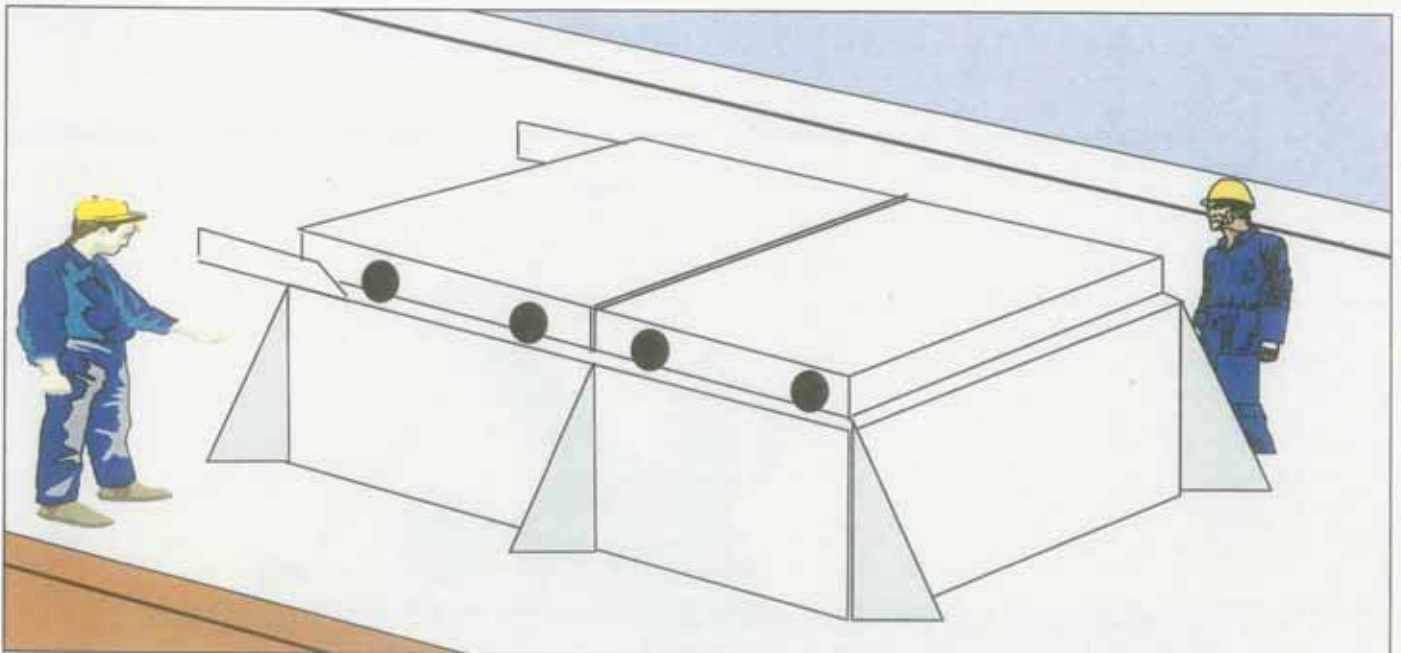

- Position crewmembers to monitor all sides of the hatch during opening.
- Raise hatch cover to the roll position by jacks or lifting system and ensure clear of guides.

● Check towing chains are free.

● Commence opening of hatch covers, slowly at first, then normal operating speed, finally slow down to stop. Great care must be taken when opening hatch covers, especially if it is not possible to control the operating speed.

● Check that towing chains remain free and do not foul the tracks or coaming top.

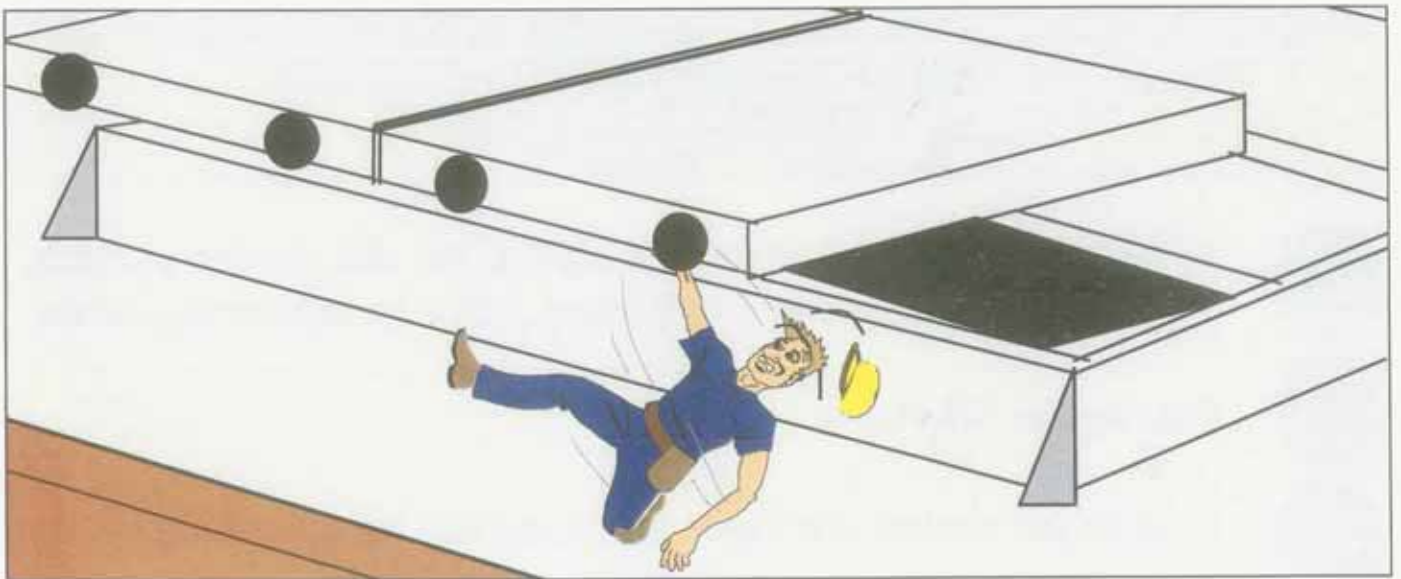

● Never attempt to clear obstructions by hand.

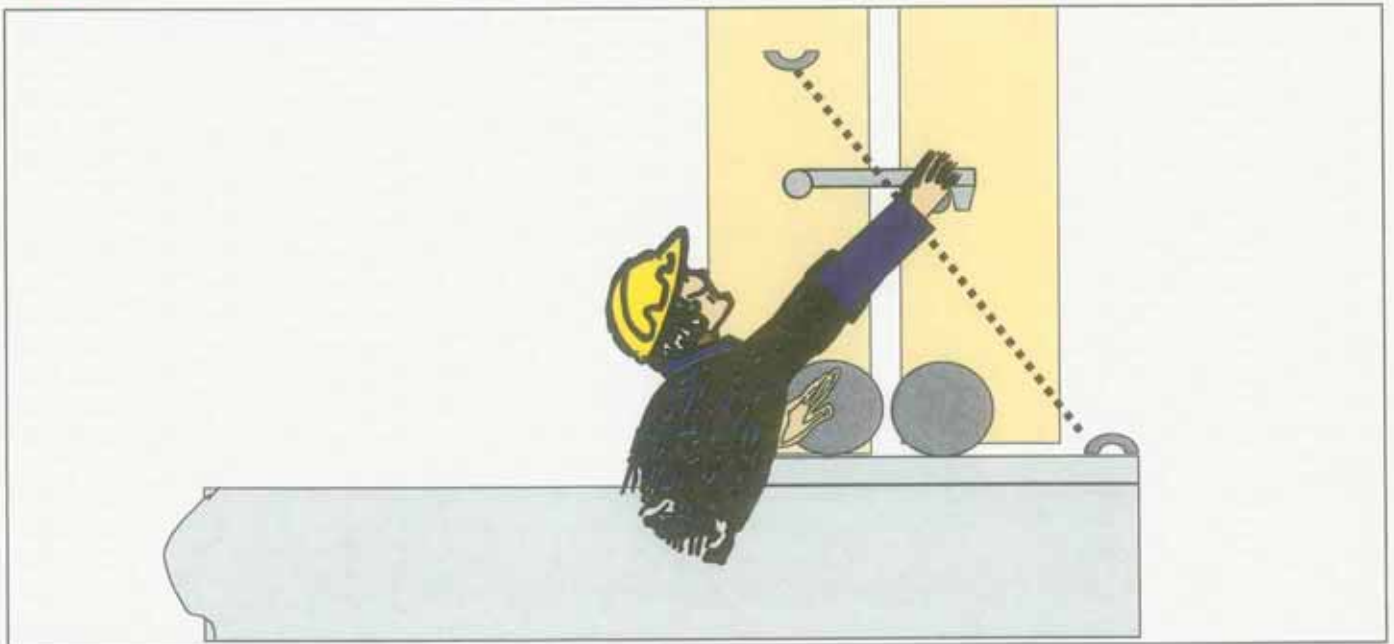

● Secure the hatch covers in the open position prior to shutting down the power or removing the towing and back-haul wires.



- Install portable handrails where fitted. N.B. this should be done at the appropriate time according to type.

Closing

- The Officer of the Watch should be informed prior to closing any hatch cover.



- Ensure the coaming top is clear of cargo, debris, tools, etc.

- Ensure that the drain channels and entrances to the drain valves are clear.
- Check that hatch covers and seals are free of defects.
- Check that any damage to wheel tracks, compression bars and landing pads has been repaired.
- Ensure the hold is clear of personnel and that the hold access hatch or door is open. Check towing chains are free.
- Switch on power system.
- Attach towing wire and back-haul wire.
- Remove portable handrails where fitted. N.B. this should be done at the appropriate time according to type.
- Release locking or stow hooks and wires.
- Position crewmembers to monitor all sides of the hatch during closing.
- Ensure personnel are clear all round the hatch.
- Commence closure of hatch covers, slowly out of stow, then normal operating speed, finally slowing as the hatch cover nears the closed position. Great care must be taken when closing hatch covers, especially if it is not possible to control the operating speed.
- Check that towing chains do not foul the tracks or coaming top. Never attempt to clear obstructions by hand.

- Lower hatch covers into guide pockets by jacks or lifting cylinders. In some cases this happens automatically by means of ramps.
- Attach cleats prior to removing the towing wire or closing down the power.
- Finally, check no one is in the hold and secure all hold access hatches, grain hatches and hold entry points.

Special Points to Note Concerning Hatch Openings and Hatch Covers



- With hydraulic systems always ensure the oil tank is kept filled to the operating level and with the correct oil.

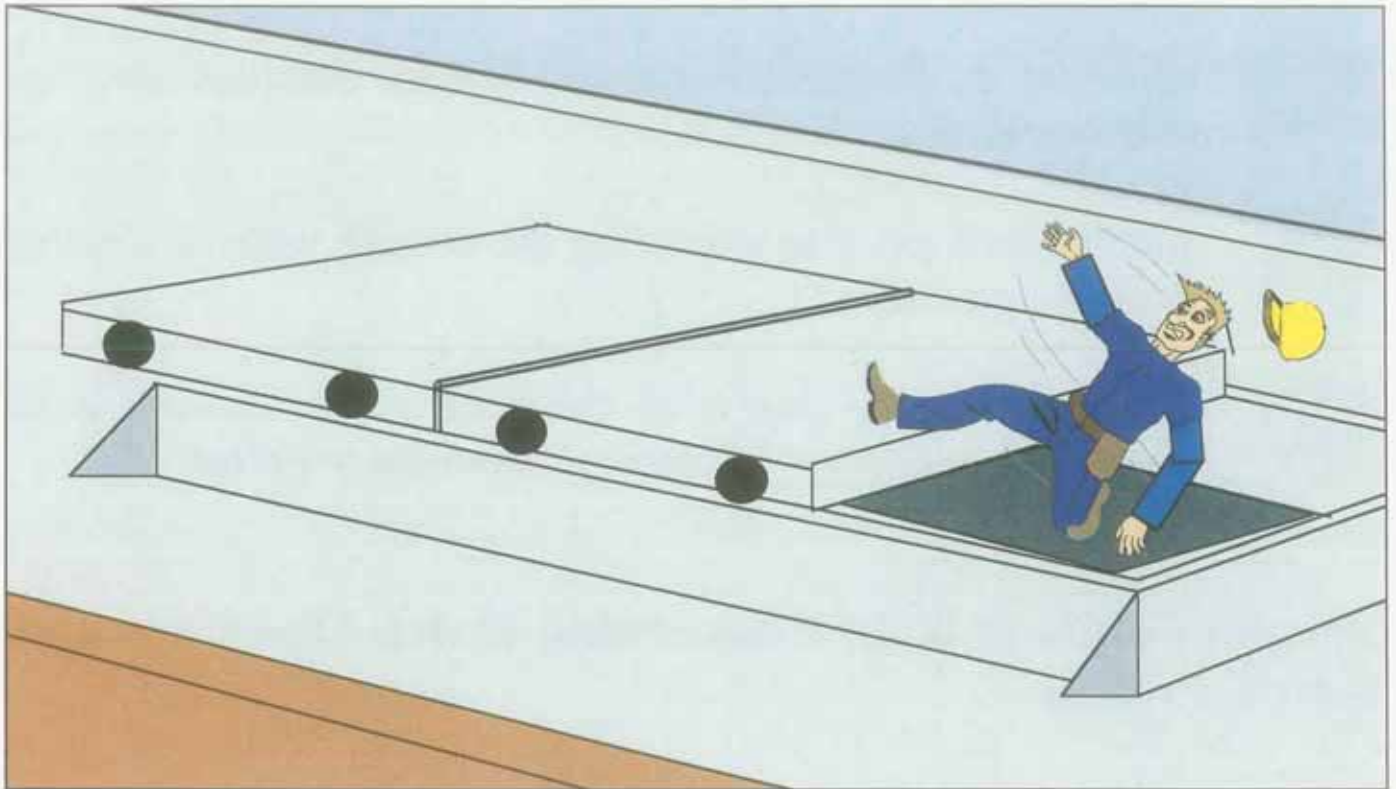

Never stand on moving hatch covers or next to unguarded openings into the hold.



Do not attempt to view the hold contents over the coaming prior to locking the hatch covers fully open.

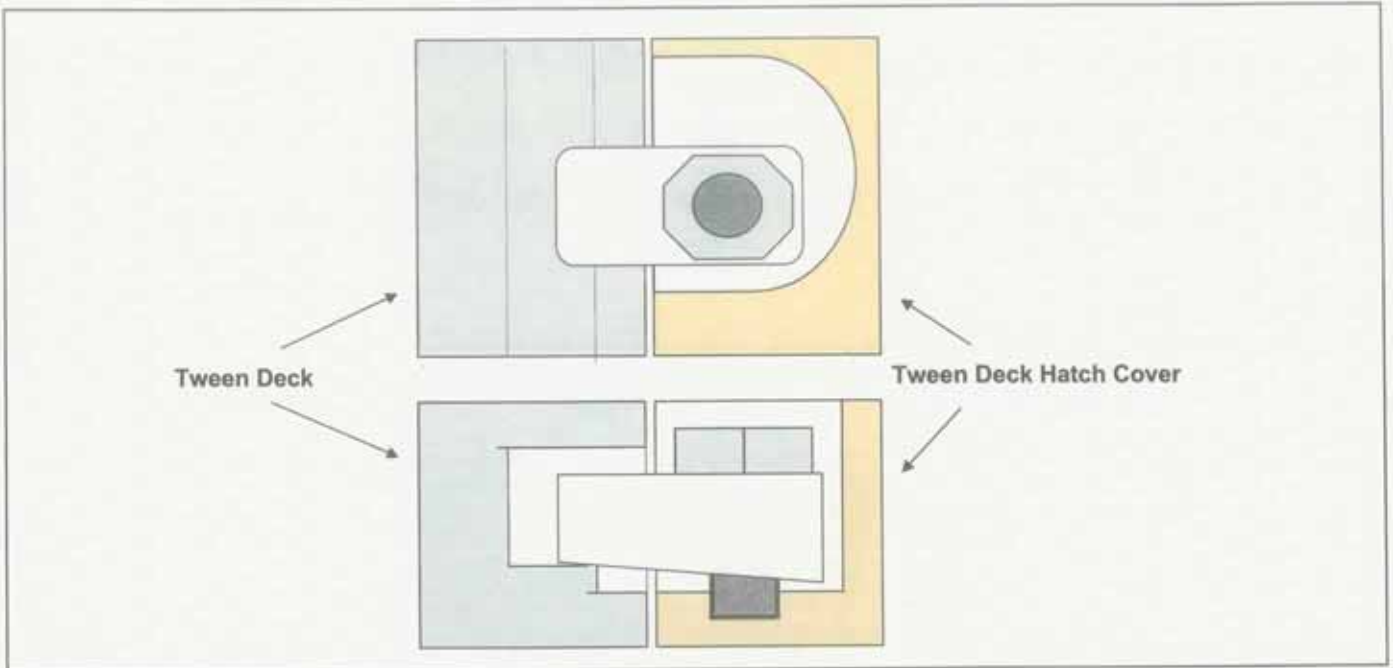

'Tween deck hatch cover cleat mechanisms must be engaged at all times when the panels are closed.



Never open hatch covers at sea unless absolutely necessary. Then, always secure by lowering wheels into guide pockets and/or attaching wires; particularly if side rolling type.



Do not tighten cleats so that the panels are unable to move on the coaming. This can cause weld failures on covers or coamings and lead to leaks. Follow maker's instructions.

Preventing Accidents to Personnel

Think!

Always follow your Company's instructions for entering and leaving holds, but watch for these basic points:

- Check the toxicity of the atmosphere in the hold prior to entry. If in doubt, ventilate fully.



- If entering the hold alone, always ensure someone else knows you are there and leave a prominent notice at the hold entrance.
- Check the lock-back mechanism on the hold access door or manhole is operational.



- Never lower oneself on to the hold ladder by grasping the hold access door for security.

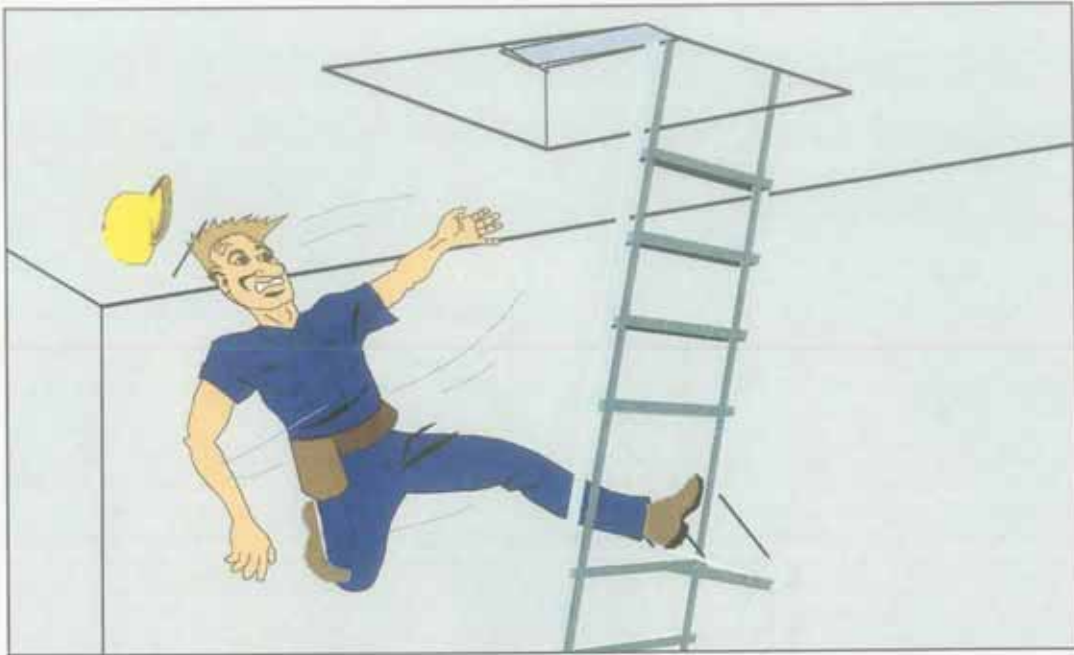

Do not use damaged or unsecured ladders, except in emergencies and then only with a secured safety harness.

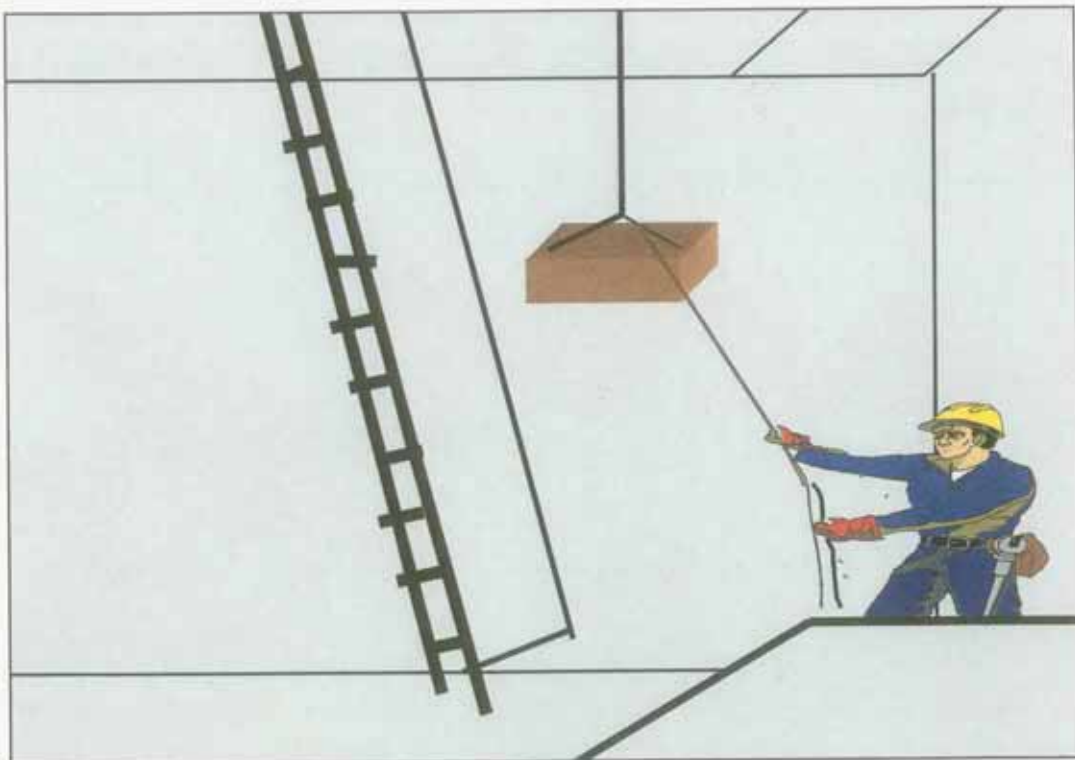

Never carry tools or equipment while descending or ascending a ladder. Always have both hands free for climbing up or down ladders; lower or haul tools and equipment by rope.

Check lighting is adequate, particularly at the bottom of the ladder. If the hold is unlit, use a powerful torch attached to a sling or strap across the shoulder.



- Never climb on top of bulk cargo without a lifeline and an assistant at the coaming side who can observe you at all times.



- Never smoke in a hold, as cargoes sometimes give off flammable gases.



Never stand on the coaming top when the hatch covers are open.



Always wear protective headgear when working.



Do not stand under clear openings.



Always wear protective boots or shoes for working on deck.

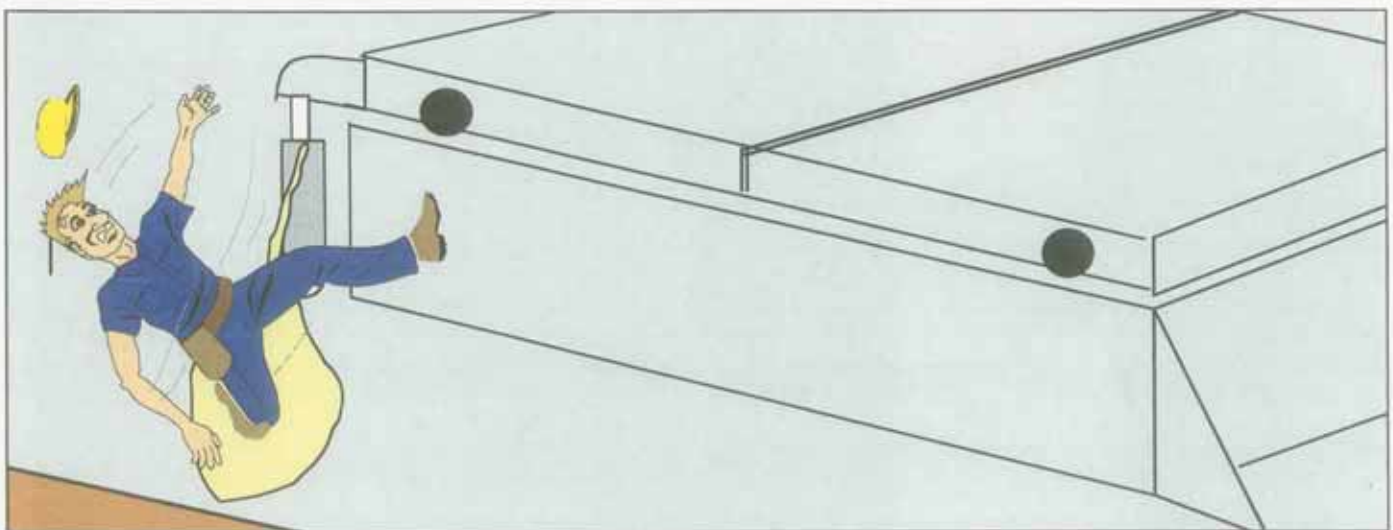

Always clean up oil spills. If the leak cannot be immediately stopped, build a save-all around and regularly empty it.

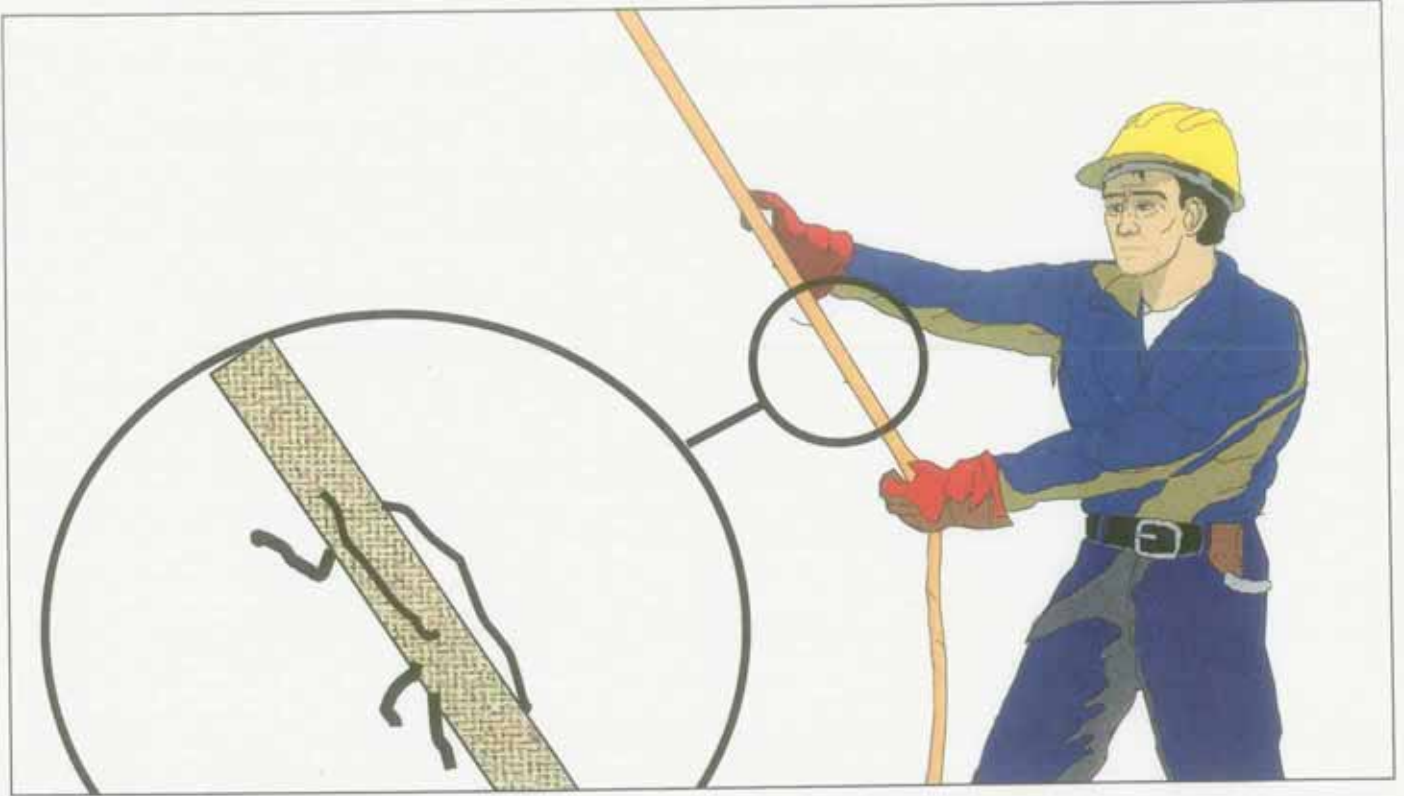

Inspect wires for wear, kinking or broken strands at regular intervals. Exercise extreme care when handling wires.

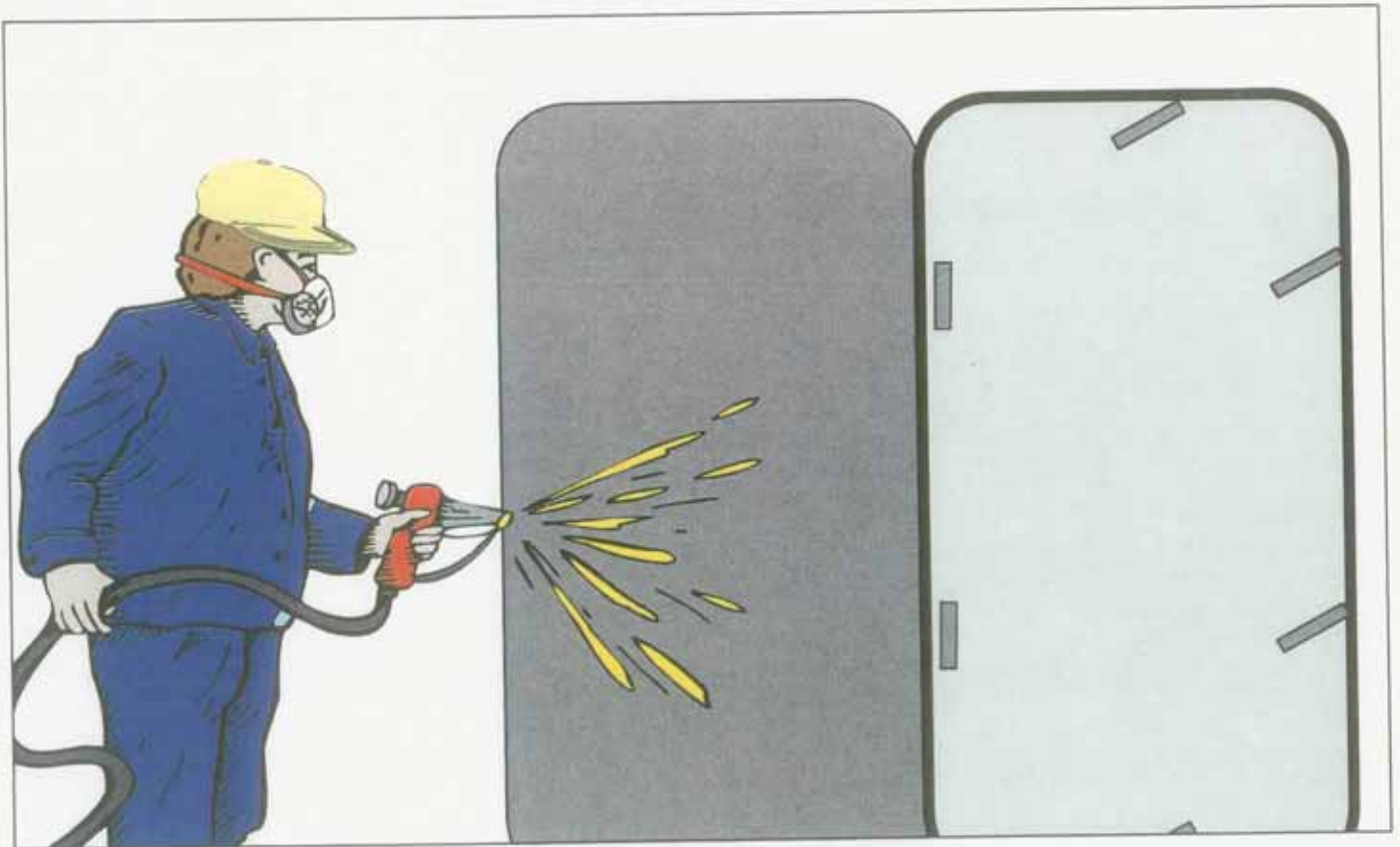

Always take precautions when fumigating.

Examples of Cargo Damage and Problems



Improper packaging, stowage and/or segregation - Specific instructions should be followed.



Pre-load tests and fumigation may be necessary.



Improper ventilation - Specific instructions should be followed.



Inherent vice - Expert advice and pre-load tests may be required, as this photograph of blackened grain shows.



Never use water to fight a cargo fire without checking first. Certain cargo properties mean that some fires cannot be extinguished with water as water actually feeds the fire.



Pre-load cargo defects - Cargo should be checked prior to loading where necessary.



Temperature problems - Temperature control plant, insulation and stowage checks may be necessary.

Testing and Inspection for Cargoworthiness and Seaworthiness

Be your own surveyor - check it all before the external surveyor arrives - be ready!

It is not enough to be right only at inspection time!

Arrange tests in good time to correct defects prior to external survey or loading cargo.

Plan inspections in good time to carry out repairs and cleaning required to load the next cargo.

Plan inspections in good time to carry out repairs before external surveys are due.

Plan inspections in good time to request repairs for scheduled refits or dry-docks.

Tests and inspections should include appropriate checks for the following:

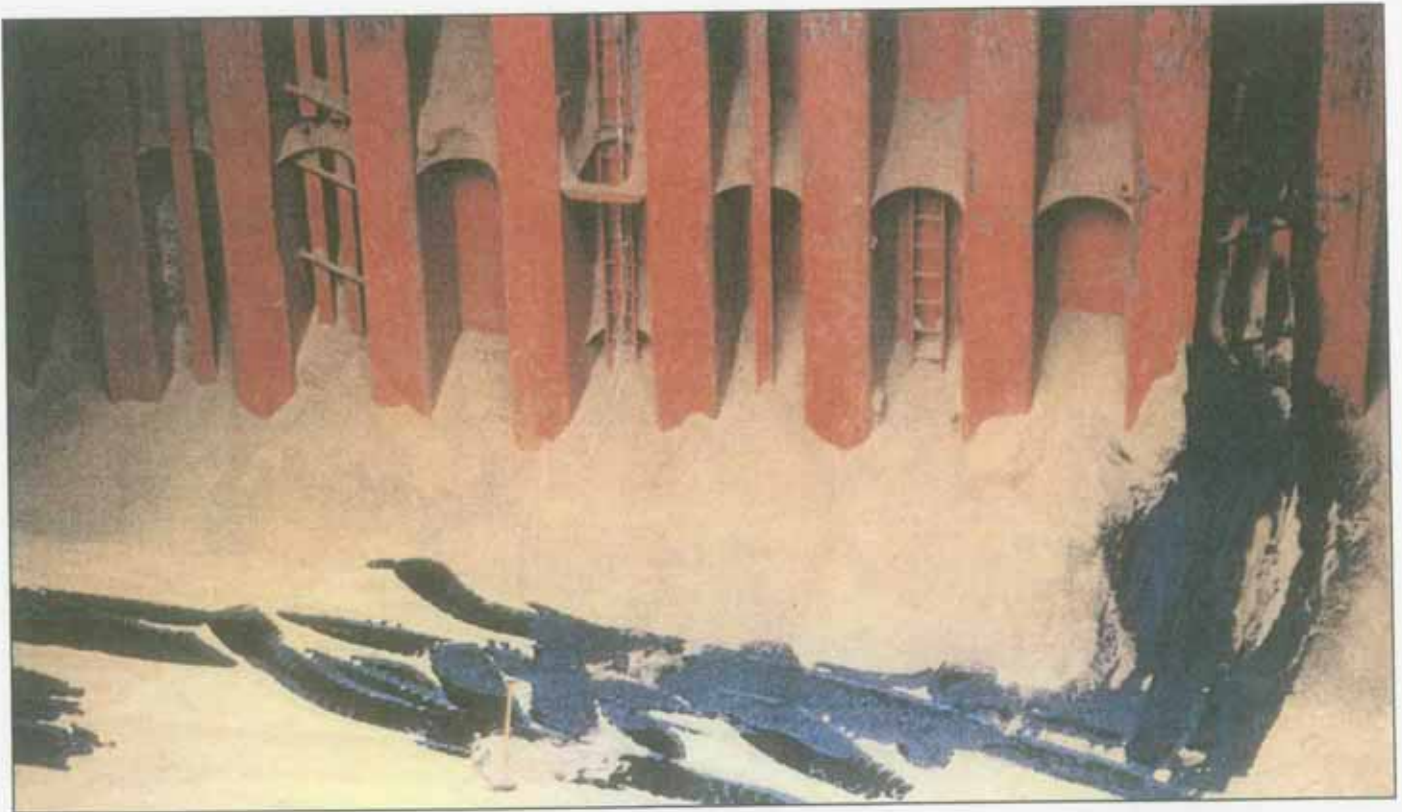

Ingress of water or oil to the cargo spaces - Safe operation and maintenance are dealt with in this book.



Weathertight integrity - Hold sides/top/bottom, pipes, trunks and sealable openings, including manhole covers (shown above) and hatch covers (shown below).



Operational performance - Cleanliness, coating integrity, moving parts and securing bolts/cleats.



- Structural Deficiencies - Corrosion or mechanical, including cracked welds.
- Fittings - Ladders, lighting, fire smothering, atmosphere monitoring equipment, etc.
- Hold bilge, ballast and sounding lines, valves, pumps, blanking arrangements and alarms.



- Double bottom sounding or vent pipes passing through holds - behind pipes often suffer corrosion holes.

Section through Cargo Hold, Coamings and Cover

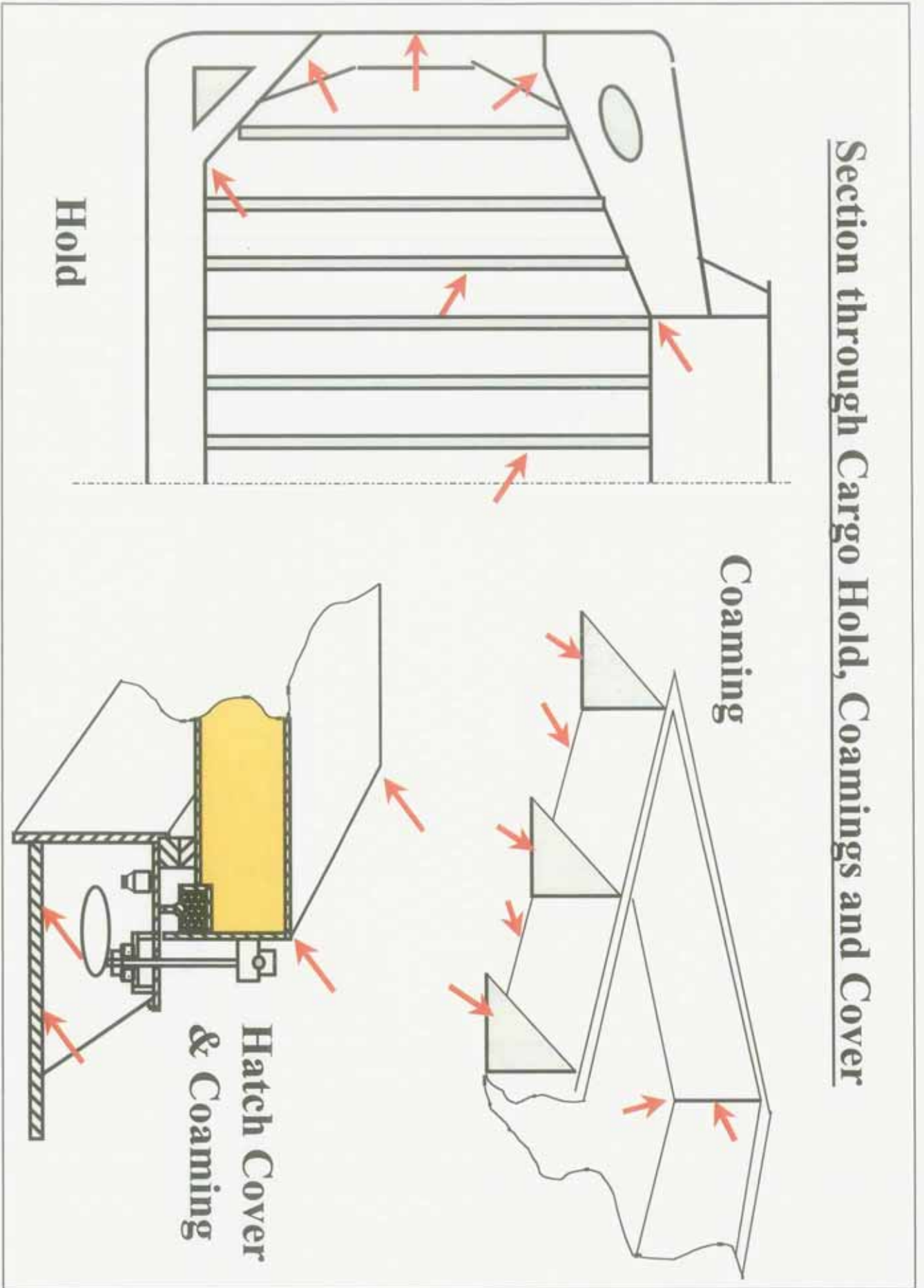

Known areas where cracking occurs.

The pairing factor - Opposite side towing chains, sprockets and hydraulic cylinders should match.



Container fittings, eye plates and lashing points - Visually and with a hammer to listen for a dull sound indicating a crack.

Stop pads - Secure to prevent panels over-running and side rolling hatch covers from being lost overboard.

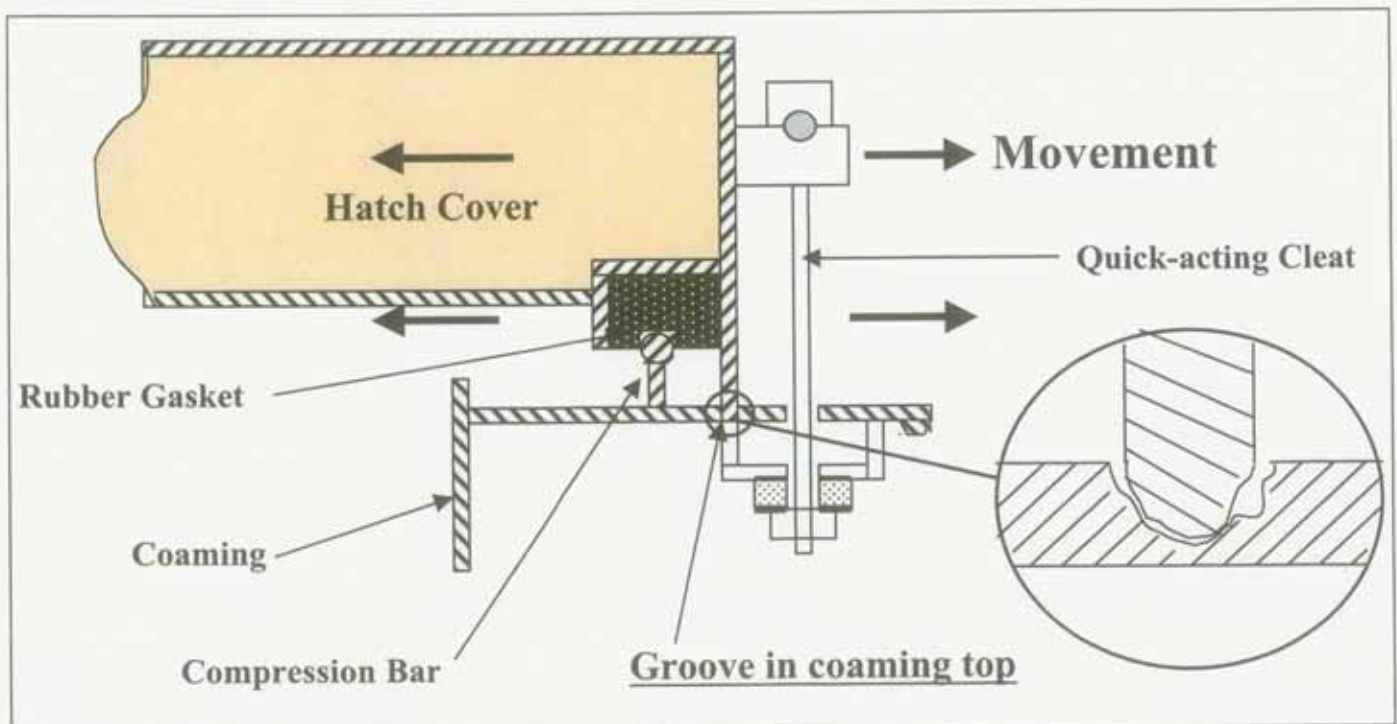

Steel landing pads - If they are worn down they can cause hatch covers to become snagged on the coaming top, causing grooving and fracturing welds.

Hatch Cover Tightness and Testing Methods

One definition of **WEATHERtightness** states that water cannot enter the hold through the sealing system.

One definition of **WATERtightness** states that water cannot enter or exit the hold through the sealing system.

Ingress Leak Test

Use the simple routine action of sighting the cargo as soon as the hatch covers are opened for signs of water damage. Take note of any water streaks or stains on the inside of the coaming.

Water-hose Leak Detection Test







This is the most commonly applied test to determine weathertightness of hatch covers.

Each classification society has its own requirements for water-hose testing.

However, a pressure of 2-3 Kg/cm², applied through a hose of 20-30mm diameter, from a 12mm diameter nozzle, at a distance of 1 to 1.5 metres and moving along the seal joint at a speed of 1 metre per 2 seconds is capable of showing any leaking joints and is a test widely accepted by makers.

Limitations or drawbacks include:



-  Possible damage to any cargo in the hold.
-  It cannot be performed in sub-zero conditions.
-  It requires the deck scupper drains to be open to clear the deck of excess water.
-  Possibility of contamination of the harbour water from deck debris or oil.
-  The test cannot pinpoint leaks on the cross-joints or side joints accurately.

Chalk Test

This test may not be acceptable to external surveyors checking for weathertight integrity.

The test is performed by covering the compression bars of the coamings and cross joints with chalk, closing and then re-opening the hatch covers to detect if a chalk mark has been left on all parts of the sealing material.

It is a test used to check the alignment of hatch cover panels with the coaming and the compression bar with the rubber packing, following repairs and renewals.

-  It is not effective in identifying weathertight integrity.
-  It does not have most of the limitations and drawbacks applicable to water hose testing.

Putty or Moulding Clay Test

This is a maintenance test mainly used by the maker's representative to precisely determine alignment and clearances.

Putty or moulding clay is placed at regular intervals in the packing retaining channels that have no packing in them. The hatch covers are closed then re-opened leaving an indentation.

This allows the exact steel-to-steel wear down condition to be calculated and any panel distortion or misalignment to be measured and remedial action taken.

Ultrasonic Leak Detection Test

This test verifies the weathertightness of hatch covers, doors and hold access cover seals.

Class approved equipment may be used to carry out mandatory surveys.



This test requires a signal generator to be placed inside the hold with the hatch covers closed and a sensor being passed round all compression joints to the outside.

- One man can conduct this test.
- The test will identify ANY leaking points from joints or holes in steelwork to a precise location.
- This test also overcomes most of the limitations and drawbacks applicable to water hose testing and, if carried as ship's equipment, can give a good indication of future maintenance requirements to ship's staff.

Limitations or drawbacks include:

- The equipment requires an experienced, preferably certificated, user to interpret the readings correctly.
- The equipment requires regular calibration, usually yearly.

N.B. Some of this equipment is suitable for shipboard use in machinery plant leak detection and vibration monitoring, giving further indication of future preventative maintenance requirements in areas other than weathertight integrity.

Tolerance Test of Hatch Cover Panels

This test is conducted on a jig to check the flatness of adjoining panels, as well as the dimensions and the hinge pin clearances where multiple panels are measured. It also checks cross joint steel-to-steel contact wear down.

It is a test done following extensive steel repairs to hatch cover panels and is essential if the panels are of double skinned construction.

Always contact the makers for such testing, as original construction information is needed.

Maintenance and Repair

Routine checking, adjustment and renewal or repair will cut overall costs. Poor maintenance in holds and of hatch covers leads to leakage and potential damage to cargo. This can result in higher insurance costs, loss of reputation, loss of leverage negotiating freight rates or even loss of business.

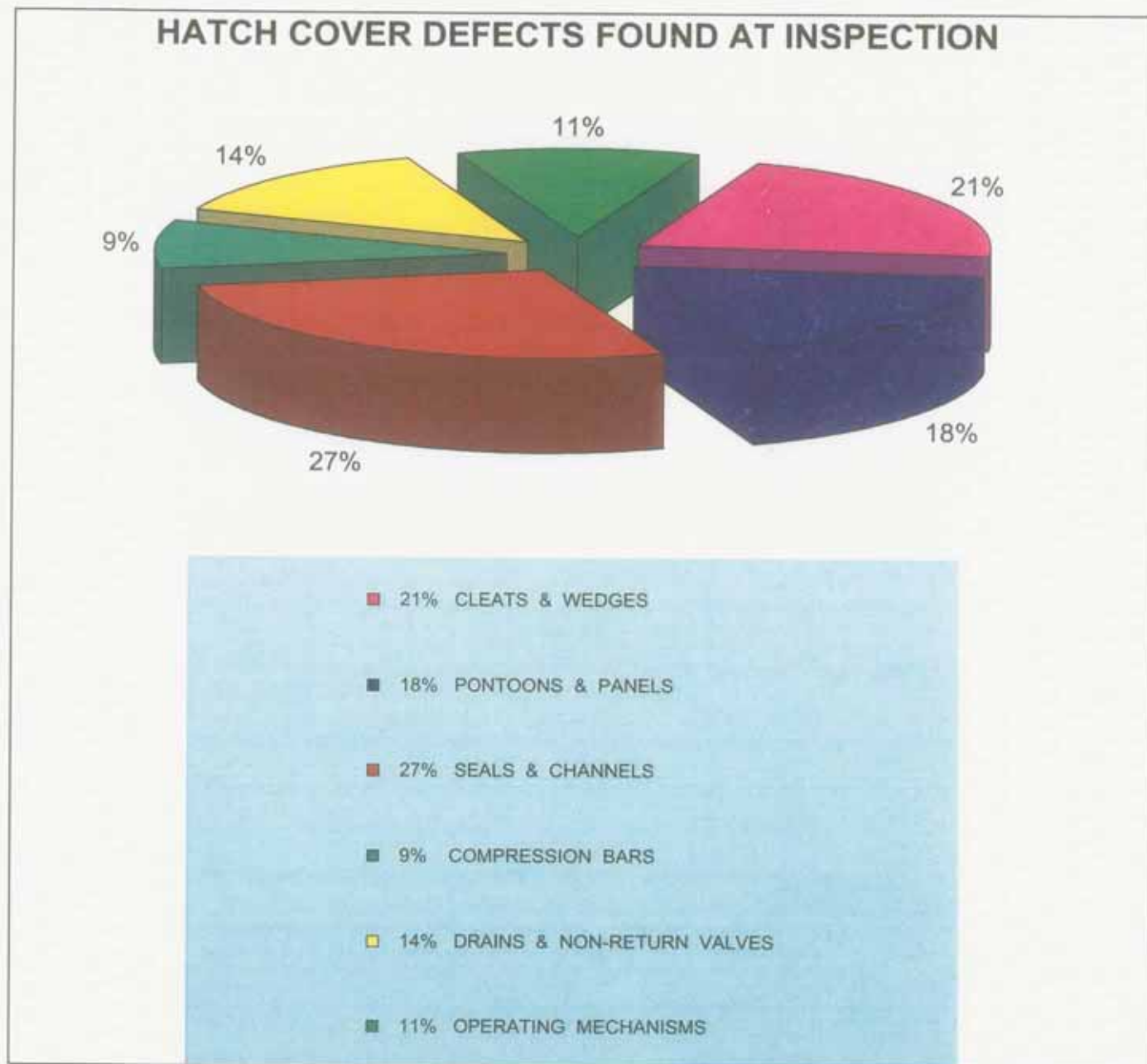

A maintenance programme should cover the entire hold, hull internals, fittings and hatch covers.

Use maker's instructions or draw up a checklist for the vessel.

Cover the inspection points essential for full maintenance.

Against each item record the condition or action taken.

PANEL									
Panel No. / Pos'n	Date Exam'd	General Condition of Structure (Evidence of corrosion to be noted)				Condition of Wheel Assembly			
		External	Internal	Report	Action	Examined	Greased	Report	Action

PERIPHERAL JOINTS									
Panel		Seal				Cleats			
No.	Pos'n	Date Examined	Tested Yes / No	Report	Action	Date Exam'd	No. Along Joint	Report	Action

CROSS JOINTS										
Between Panel Face Nos.	Drain Holes			Seals				Cross Joint Wedges		
	Date Exam'd	Report	Action	Date Exam'd	Tested Yes / No	Report	Action	Date Exam'd	Report	Action
1A-2F										

HATCH COAMING							
Position	Date Exam'd	Coaming		Compression Bar		Landing Pads	
		Condition	Action	Condition	Action	Condition	Action
Forward							
Port							
Aft							
Starboard							

Typical checklist formats for hatch cover and coaming routine maintenance.

Routine Maintenance 1 - After Each Cargo Operation

- Clean the coaming tops and remove any debris or equipment.
- Clear drain line holes and valves of debris.
- Drain valve caps should be attached by chain, but not screwed on. They must be ready in case of a fire in the hold or when carrying out fumigation operations.

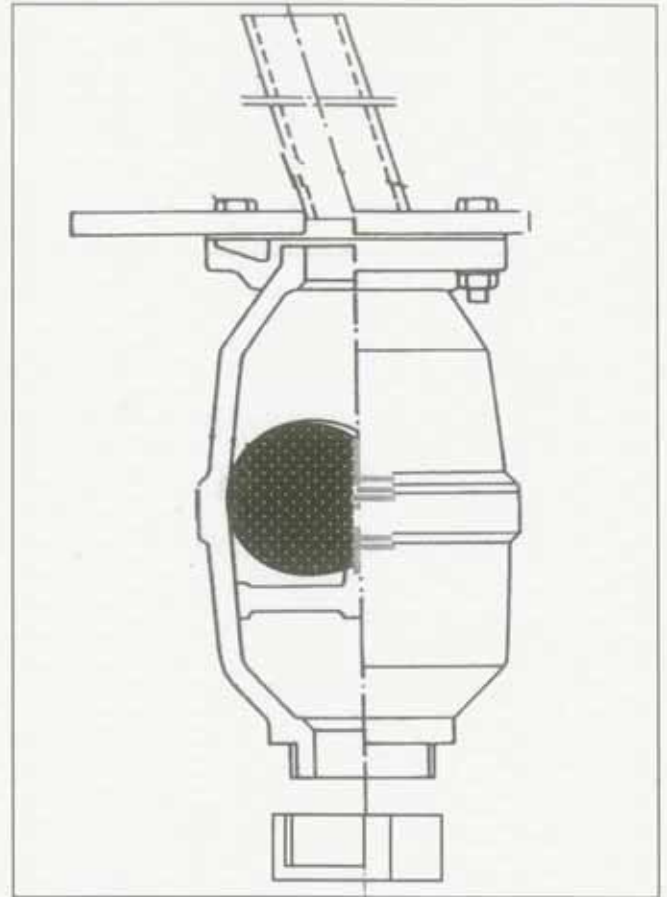

Photo: MacGREGOR



- Whilst cleaning, check for coaming damage and wear, particularly on compression bars, landing pads, wheel track and the coaming top for any grooving. Record faults for urgent or future repair, as appropriate.
- Grooves and worn landing pads can be built up with weld and ground down, as required, giving a permanent repair.



Check and clean the surface of the seals and take special care if the cargo is dusty or gritty.

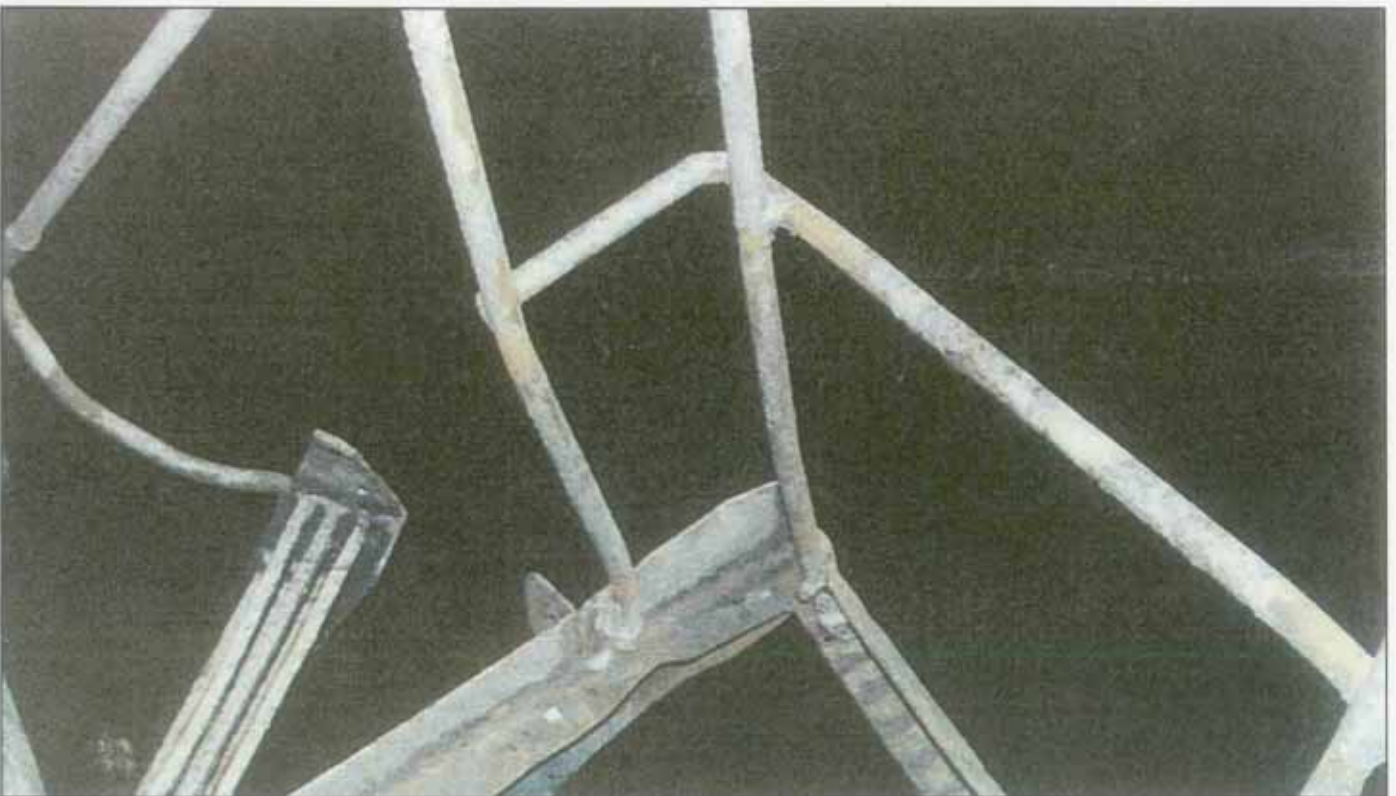

After discharge check hold internals, including ladders, sounding pipes, brackets and inner coaming surfaces for mechanical damage.



Check sounding pipes are clear and undamaged.



Check hydraulic system for leaks, especially couplings, valve blocks, piping and flexible hoses. Repair as necessary.

If hydraulic cylinder seals fail, it can require the removal of the cylinder for repair. This can involve the burning out of the heel pin brackets.

- The maker's representative should be called in to carry out realignment of hydraulic cylinders, if burned out.
- Check coaming weld seams for damage caused by grabs or cargo and arrange repair, as appropriate.
- Check for rust streaks on the inside of the coaming which would indicate a leaking hatch cover, then take any necessary remedial action. Clean off the old rust streaks and stains.

Routine Maintenance 2 - Three Monthly Intervals

Mechanical Items

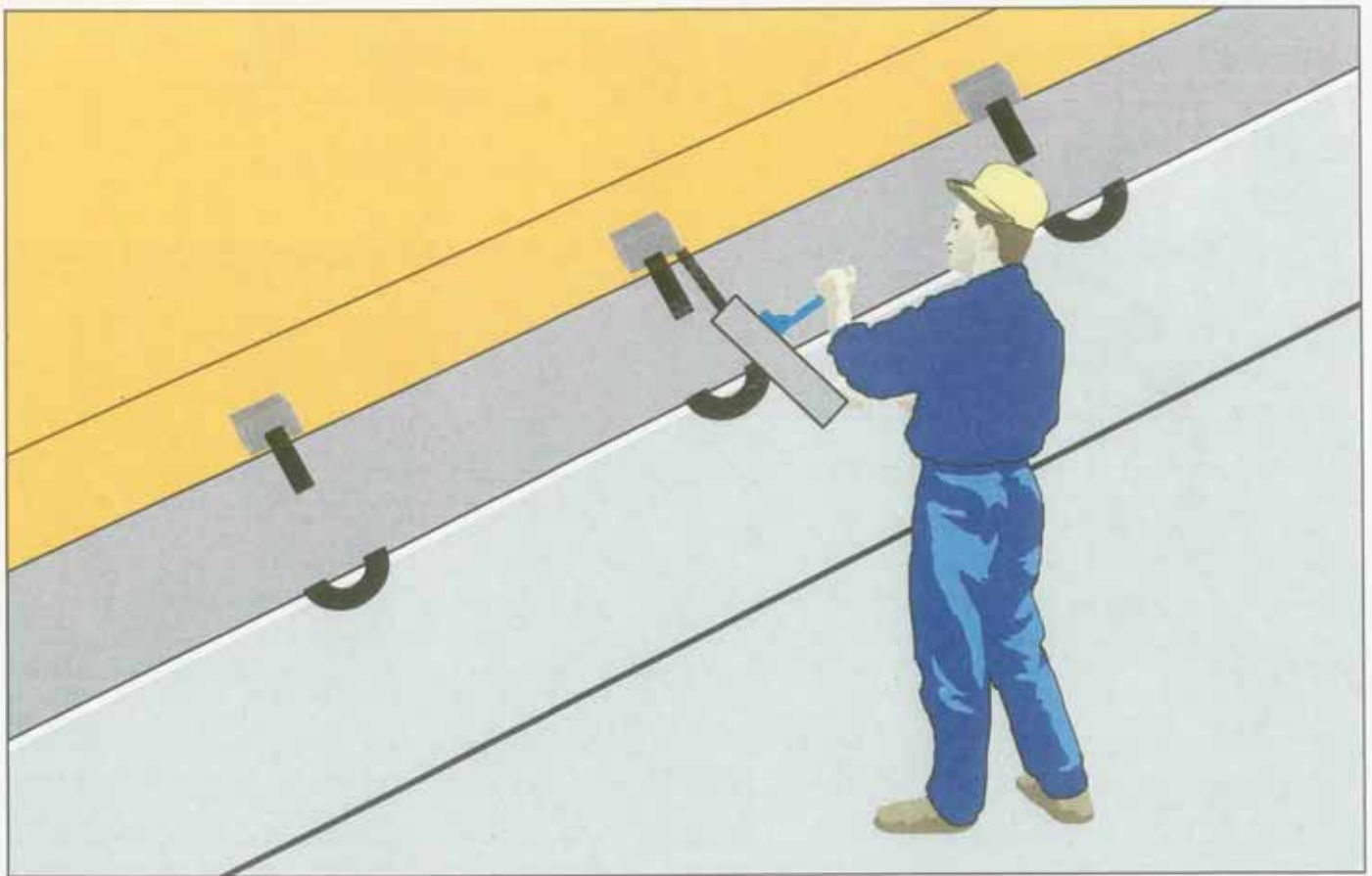

- Grease wheel spindles, cleat spindles, hinge pins and hydraulic cylinder protective sheaths.
- Check hinge pins for wear and repair as necessary. Worn hinge pins can cause slewing of panels and leaking cross joint seals.

Grease cleat wedges, drive chain sprockets, toothed racks and cylinder spherical bearings.

Check and adjust drive and towing chain adjusters.

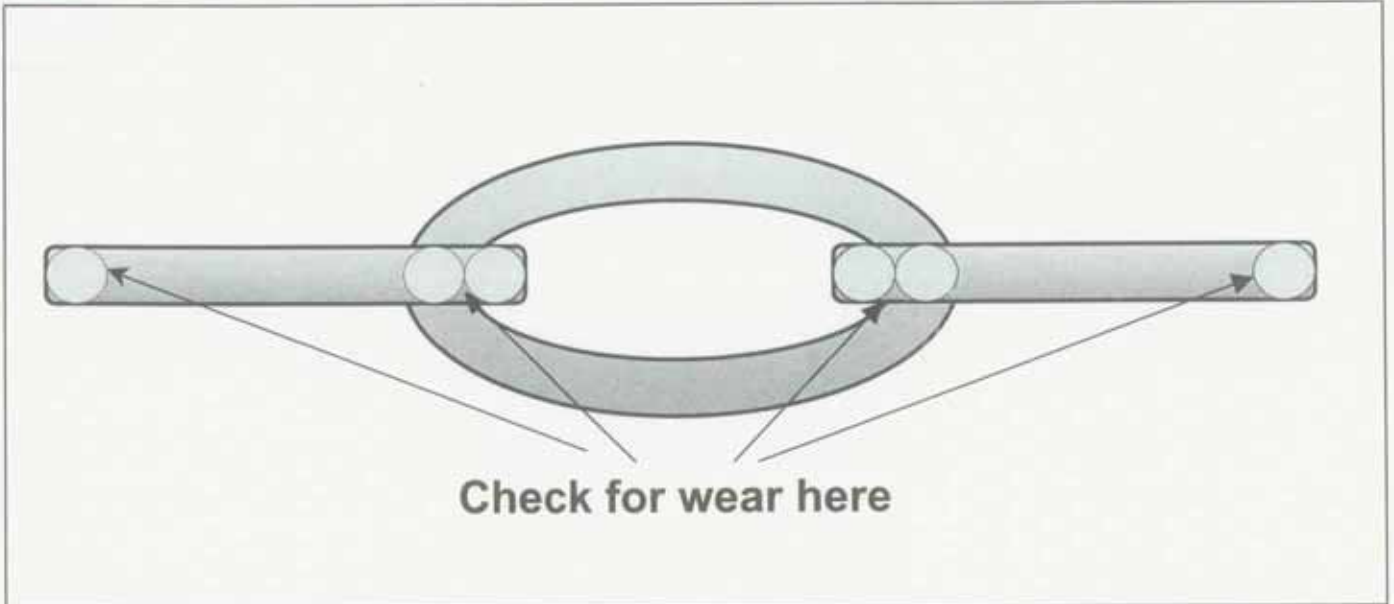

Ensure hatch cover link pin bushes and chains are not worn or out of adjustment.



Photo: MacGREGOR

Towing chains between panels should be adjusted or renewed in pairs and never twisted to create equal lengths. Either take out links or add links.

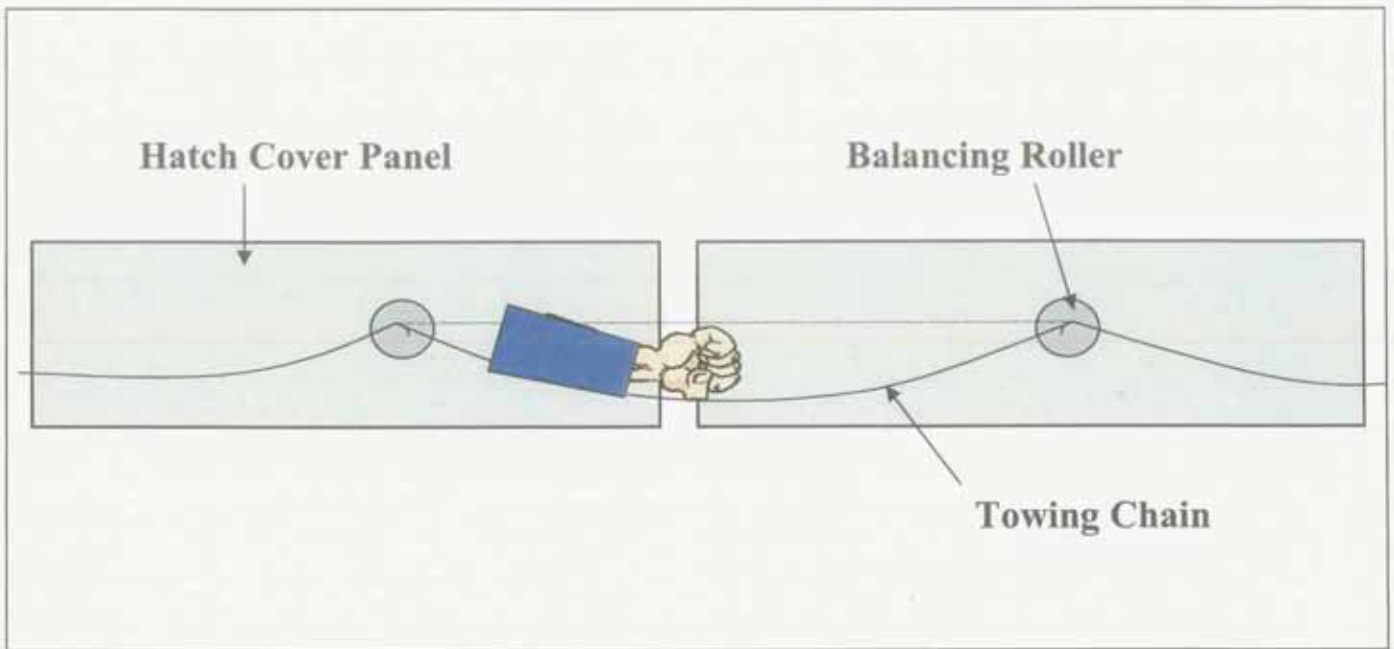

- The maker's instruction manual will provide accurate length measurements for the chains but, if these are not available, the sag in the chain should be equal to approximately a fist width at the mid point as shown above.

- Adjust cleats. The correct adjustment is one 360-degree turn on the nut after making contact with the steel washer.

- Further tightening will NOT improve the weathertightness of the hatch cover.

Seals

- Check rubber seals for elasticity, mechanical damage or permanent deformation.

- Hatch covers usually make steel-to-steel contact when a compression bar indents rubber seals by 12-16mm. Check maker's manuals or with the maker for exact compression.

- When the hatch covers are opened the rubber should almost retain its original shape, although new rubber will invariably suffer a 1 or 2-mm permanent set after the first operation.



- Once the permanent indentation reaches 70 per cent of its designed compression then the hatch cover is likely to leak.
- DO NOT grease the rubber packing or seals, unless proceeding into arctic conditions, when glycerine based grease can be used on the compression bar to prevent sticking of the packing.
- Ensure seals are free of any paint and, when painting hatch covers, protect seal surfaces from paint adhesion.
- Cross joint seals are the most likely to need renewal, with side panel joints next. Hatch cover end joints rarely require renewal unless they have suffered impact damage.
- When renewing rubber it is important to check that all steelwork is in good condition and that clearances are within tolerances.
- Hatch cover hinges and wheels should not have excessive play and landing pads should be checked to be within tolerances.
- The rubber retaining channels and compression bars should be substantial, straight and rust free.

- Failure to check the touching components, at the steel-to-steel and the rubber-to-steel contact points, can result in over-compression, distortion and tearing of newly fitted rubber; leaving it useless within a very short period.
- Only fitting new rubbers is misguided and can be very costly to the ship owner, both in monetary terms and also loss of charters and reputation. Steelwork repairs must be done.
- When renewing rubber always clean out the rubber retaining channel properly, coat with compatible anti-corrosive paint and use the special adhesive supplied by the maker.
- Always renew the total length at the first opportunity, i.e. entire cross-joint or entire side/end.

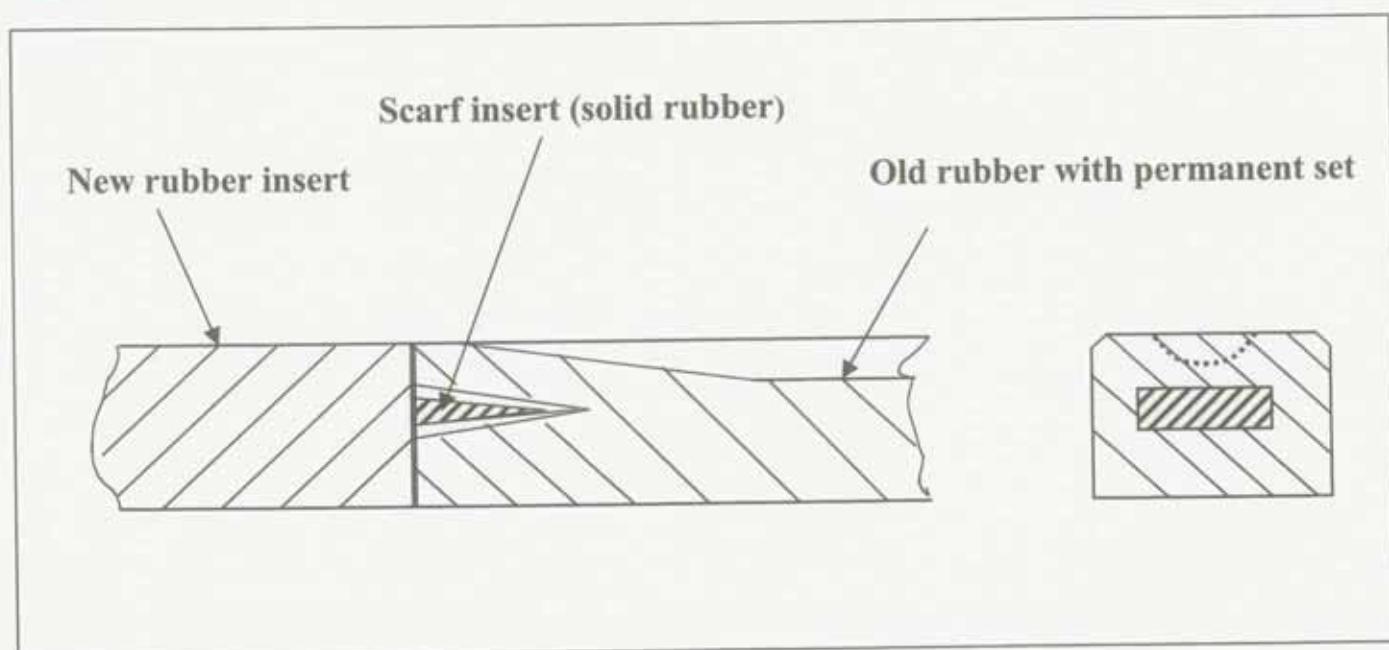

- If short lengths are to be renewed in an emergency, scarf in the new section, never less than 1 metre length, in the approved manner (see diagram) to raise the seal surface of the old rubber to that of the new.
- Renew corner joints and pads before straight lengths.
- If you have no spare rubber seal, the existing rubber can be packed out with a backing rubber 5 or 10 mm thick to assist in recreating rubber compression as a short-term repair.

Always repair rubbers rather than using hatch tape. Regular use of hatch tape ultimately leads to localised heavy corrosion and even worse weathertightness problems.

Hydraulic System

Check header tank oil level. Top up as necessary.

Take oil sample; allow to stand in a glass bottle and check for water, layering of oils or debris. Renew the oil charge, if necessary.

Renew filter unit cartridges, particularly if maintenance has been conducted on the system components.

Check any hydraulic valves for leakage.

Check the balance of hydraulic cylinder valves. Incorrect balance can cause panels to twist and fall into the hold.

Flush the hydraulic system every five years or after major maintenance. This should be carried out by specialists.

Structure

Check hatch cover towing attachment plates, steel structure around container stools, lashing points and cleat crutches for cracking of welds or corrosion.

Photo: MacGREGOR





- Pay special attention to the hydraulic cylinder brackets, attachments and coaming stools. Check for any signs of undue wear, distortion or cracking.
- Check condition of steel-to-steel landing surfaces at cross-joints and side panels. Leaking cross-joints are the main cause of water entry into the hold, therefore proper steel-to-steel contact and correct compression maintenance in that area are essential.
- The most common cause of rubber packing failure is badly maintained steel-to-steel contact.



Photo: MacGREGOR

- Originally, adjoining panels' top plates will be set level with one another. Any deviation from this must be remedied by attention to the steel-to-steel contact points.

● Check ladder and handrail welding.

● Check ventilators will turn and seals are intact.



● Check fire dampers will operate. Free any seized spindles and grease well.

● Check hold access door locking mechanisms, door seal and lock-back mechanism.

● Check closing plates on air pipes and sounding pipes.



Routine Maintenance 3 - Nine Monthly Intervals

This section of the maintenance programme should be performed in addition to Routine Maintenance 1 and 2.

- Check quantity and condition of spares carried on board.
- Note that rubber packing and rubber adhesive have a limited shelf life and should normally be date stamped when purchased from the original maker.
- Check condition of the hydraulic oil in the system by analysis.



Photo: MacGREGOR

- Check safety locking devices and hydraulic system cutouts. Test them in operation.
- Check the welding at deck level of all sounding, filling and air pipes.
- Check hold ladder stays, their welded attachments and make good any defects.
- Note any changes from previous reports and any defects requiring attention or permanent repair at the next repair period.

Pre-docking Checks

- Three months prior to a major dry dock or repair period, carry out all the checks set out above, including an ultrasonic or hose test.
- Make a list of all repairs and tests to be made in dry dock and order any spare parts required.
- Check the frames on the underside of the hatch cover panels and the steel condition in way of the cross-joints. These are the areas where major defects are most likely.

Pre-delivery Checks









- Carry out a full periodic check of the holds and hatch covers and record the results of the inspection and any maintenance or repairs done before delivering a vessel to a new charterer.

Repairs, Emergencies and Normal Practice

- Repairs to steelwork should always be done by a competent welder and to the satisfaction of the ship's classification society.
- Doublers that have been put on failed steelwork as a temporary repair may require inserts to regain the designed strength of the area.
- At regular intervals arrange with the maker's representative to attend in order to accurately determine any wear down, misalignment or other problems with hatch covers.
- Rubber backing strips, inserted into retaining channels as a temporary repair, must be removed when replacing rubbers after steel-to-steel repairs have reinstated clearances.
- The internal atmosphere of double skinned or box type covers is inerted during construction to prevent corrosion. This must be renewed by the maker's representative after any repairs.

Do's and Don'ts

- ALWAYS rectify steel-to-steel faults before renewing rubber packing or rubber renewals will not be effective.
- ALWAYS keep chains and cleats correctly adjusted.
- ALWAYS attach locking pins and chains to doors and hatch covers in the open position.
- ALWAYS keep coaming tops clean and double drainage channels in good order.
- ALWAYS open hatch covers and clean coaming tops and double drainage channels after loading bulk cargo through the grain or cement hatches. This must be done prior to final closing of covers for sea.
- ALWAYS keep wheels, hinge pins and chain tension equipment well greased.
- ALWAYS keep hydraulic systems oil tight.
- ALWAYS give notice that maintenance is being performed on equipment. Ensure no one can start the system or equipment.
- ALWAYS prevent access hold from being locked closed when personnel are in the hold.
- ALWAYS lock hatch covers fully open before switching off power.
- ALWAYS check wires for broken strands and fraying. Grease regularly.

-  DO NOT enter a hold with suspect atmosphere.
-  DO NOT apply petroleum-based grease or paint to rubber packing surfaces.
-  DO NOT remove the rubber ball valve from drain valves.
-  DO NOT allow grooves to form in coaming tops in way of the side panel edges.
-  DO NOT use anything other than the recommended oil in the hydraulic system.
-  DO NOT leave cleats loose when proceeding to sea.
-  DO NOT attempt to open or close side rolling covers with loads or cargo debris on top.
-  DO NOT screw down cleats beyond normal tension.

This guide aims to provide simple pointers for the safe operation and maintenance of the holds and hatch covers of ships carrying dry cargoes.

Safety of personnel and care of cargo are the prime considerations addressed, but efficiency, economy and reputation are all taken into account.

The Guide is designed to assist shipboard staff in identifying the right and wrong ways of working by highlighting correct practices and pointing out potential dangers.

The generous use of photographs, sketches and simplified wording is intended to encourage use of the book by those with a limited knowledge of English.

ACKNOWLEDGEMENTS

A. Bilbrough & Co. Ltd. and the author would like to acknowledge the contributions made to this book by:

ALLWORLD Marine & Technical

IMSI (UK)

MacGREGOR Group: Internal and Cover Photographs.

THE AUTHOR

Keith Taylor (BSc., C.Eng., F.I.Mar.E., M.C.M.S.) started his career at sea, progressing to Chief Engineer before commencing shore based work. Activities from Superintendent, through Manager to International Advisor followed, all in the marine sphere. Keith then joined MacGREGOR the hatch cover specialists in 1979 as General Manager. In 1984 he was appointed Managing Director and General Manager (Far East) for MacGREGOR Navire (Pacific) and in 1989 became Managing Director and Regional Manager (Europe) at MacGREGOR (GBR) until 1996 when Keith decided to retire from MacGREGOR. Keith is now a consultant with ALLWORLD Marine & Technical and frequently performs lectures on hatch covers and their maintenance. He is often called on to give expert evidence on hatch cover problems.

May 2001